

SPX-7200\_MAN\_260528

## Cypress Suprex® TCP/IP Series - SPX-7200 Overview

The Suprex TCP/IP Extender makes it possible to install card readers far from the access control panel, by providing a network link between readers at the door or gate and most manufacturers' panels. The Suprex includes both a Remote (door/gate) unit and a Central (Controller) unit. The SPX-7200 series devices are compatible with the EXP-2000 Expansion Pairs to allow for up to 8 readers to operate on a single network connection.

Specifications			
Part Numbers	SPX-7200	816684003066	Ethernet Reader-Extender (paired Central and Remote units)
	SPX-7200C	816684005503	Ethernet Reader-Extender (Central unit only)
	SPX-7200R	816684001673	Ethernet Reader-Extender (Remote unit only)
	EXP-2000	816684003233	Optional Expansion Pair Set to connect additional reader
Physical	SPX-7200 Enclosure		4.50" x 3.07" x 2.02" / 0.445 lbs (diagram below)
	EXP-2000 Enclosure		4.50" x 2.83" x 0.94" / 0.3 lbs (diagram below)
Environmental	Storage Temperature		-40°C to 100°C
	Operating Temperature		-30°C to 60°C
Electrical	Central and Remote Supply Voltage		8-16Vdc Current 300mA
	Relays	Max Switching	220Vdc 30W (resistive) 1A / 250Vac 37.5VA 1A
		Running Spec with load	30Vdc 1A (resistive) / 125 Vac 0.3A (resistive), 1x10 <sup>5</sup> operations @ 20°C
Data I/O	Interface		Wiegand (maximum 248 bits - pass through), Strobed (Clock & Data), F/2F (Unsupervised) LED 0-30V
Network Specifications	Network Interface		RJ45 Ethernet 10Base-T or 100Base-TX (auto-sensing)
	Compatibility		Ethernet: Version 2.0/IEEE 802.3 (electrical), Ethernet II frame type
	Protocols Supported		TCP/IP, ARP, UDP/IP, ICMP, DHCP, BOOTP, TFTP, Auto IP, HTTP, SMTP Note: For standard use cases, the SPX-7200 uses TCP/IP
Range	Network	As extensive as the network (maximum of 328 feet between Central or Remote and switch/hub/router)	
	Crossover Cable	328 feet between Central and Remote	
Additional Features	SPX-7200 includes complete solution with Central (controller) and Remote (reader/gate/door) interface		
	"Quiet" bandwidth and power		
	Field-configurable network settings		
	On-board relays to control door/gate		
	Auxiliary I/O available for LED signal and door/gate/panel status signal		
	Status LED and Supervision Relay (default off) monitor network connection status		

## Table of Contents

Topic		Page
Overview and Specifications		2
Physical Dimensions and Mounting Hole Locations		4
Central and Remote Pin Layout		5
Setup and Pre-Installation		6
Indicators and Operating Modes		7
Common Configuration and Run Mode Settings		8
DIP Switch Map		9
Quick Reference for Typical Connections		10
SPX-7200 Network Settings		11
Changing Network Adaptor Settings in Windows		12 - 14
SPX-7200 Network Settings via Web Browser		15 - 17
SPX-7200 Network Settings via Telnet		18 - 20
Enabling Telnet Client		21 - 23
Troubleshooting		24
Accessory I/O	I/O Overview	25
	Central Relay Inputs	26
	Relay 1 & 2 I/O	27
	Remote Relay Inputs	28
	Relay 3 & 4 I/O	29
	LED I/O	30
	Aux I/O	31
	Remote Digital Relay Inputs	32
	Application Note on Using Supervised Contacts	33
EXP-2000: Expansion Pairs	Using EXP-2000 Expansion Pairs	34
	Central Suprex and EXP Wiring Diagram	35
	Remote Suprex and EXP Wiring Diagram	36

# Cypress Suprex® TCP/IP Series - Physical Dimensions and Mounting Hole Locations

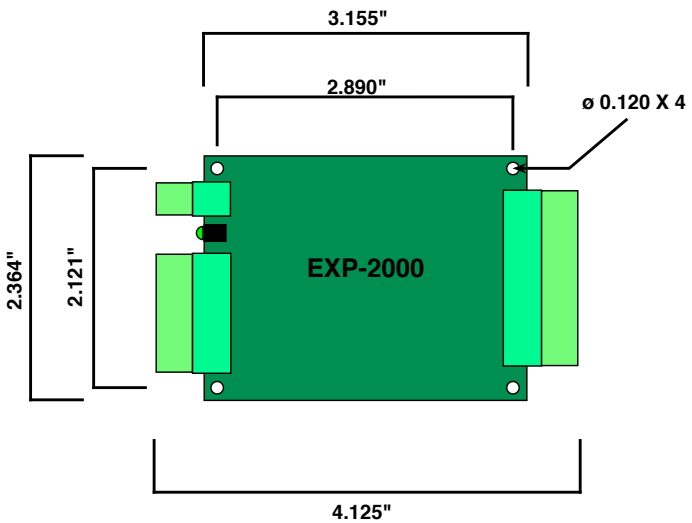
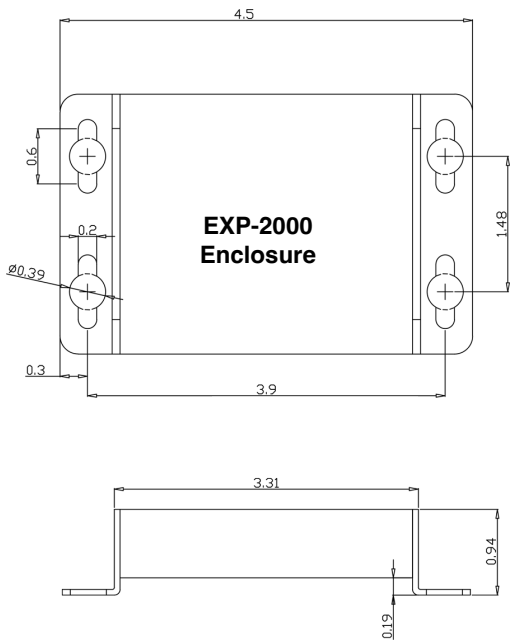
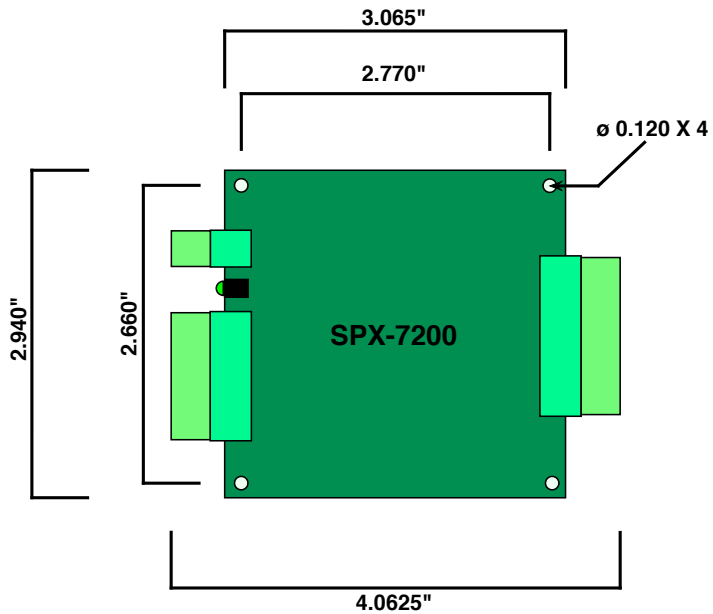
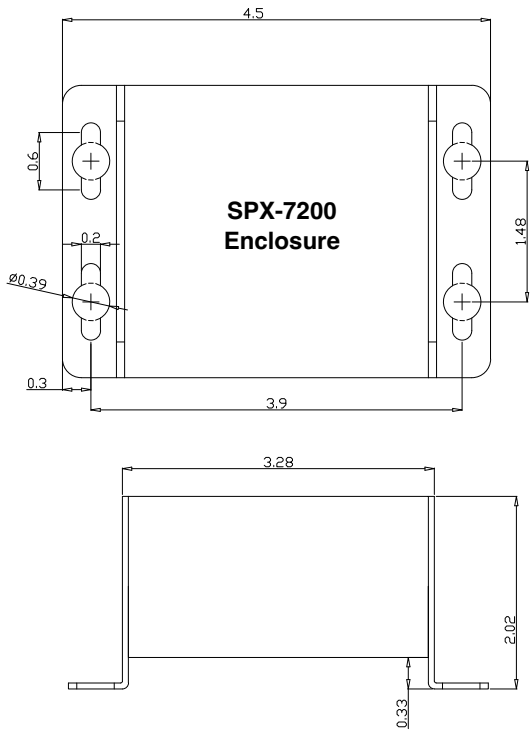

All dimensions are listed in inches.

# Cypress Suprex® TCP/IP Series - Central and Remote Pin Layout

## SPX-7200 Central

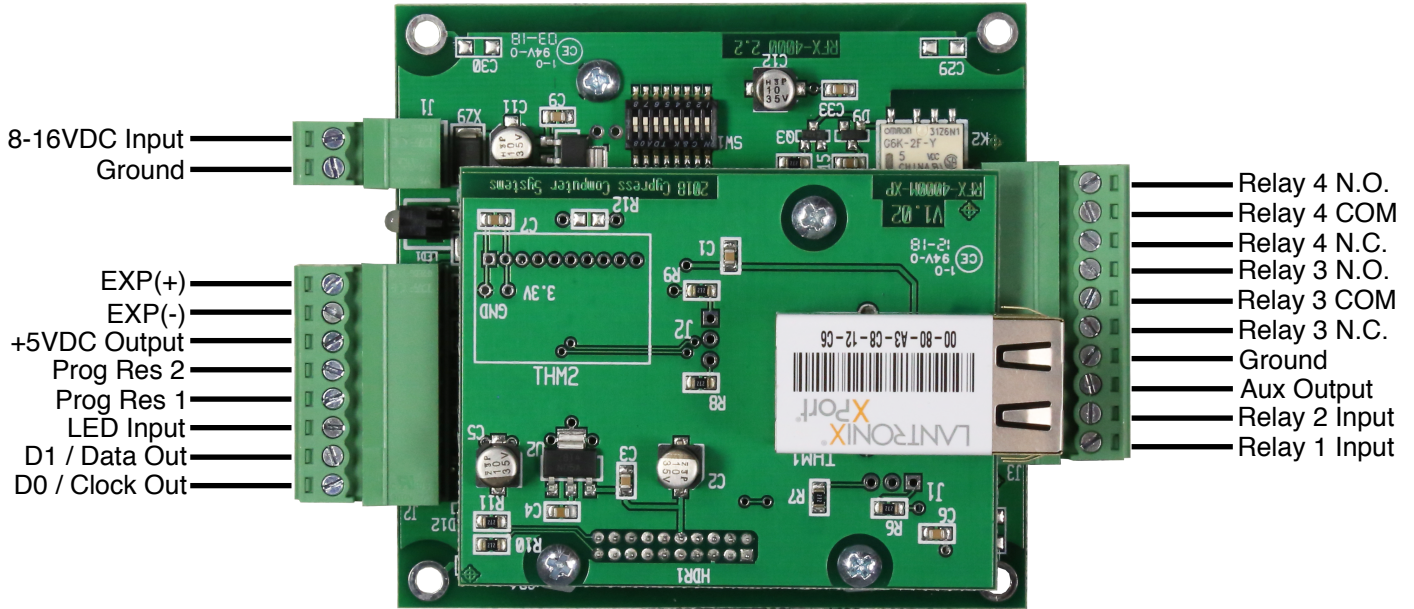

## SPX-7200 Remote

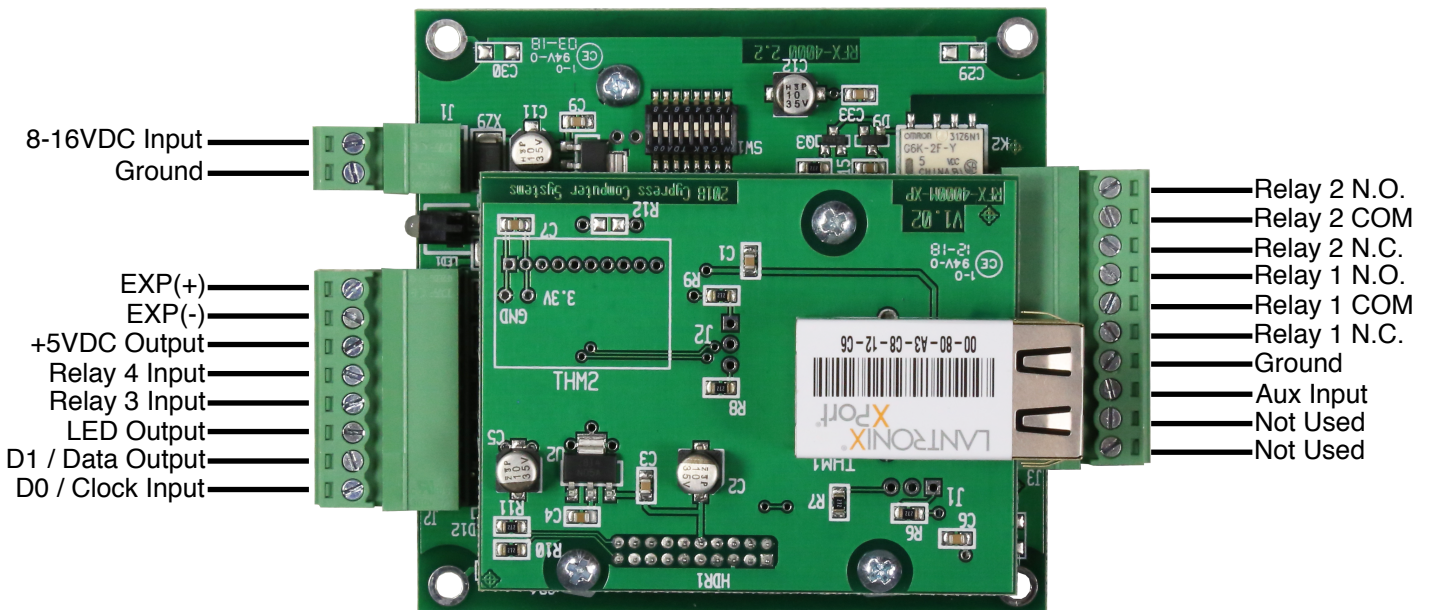

# Cypress Suprex® TCP/IP Series - Setup and Pre-installation

## Unpacking:

Remove Central and Remote units from the packaging material and check interior for any shipping damage. Inventory any included parts (depending on model) such as terminal connectors.

## Bench Testing:

Before installing the units in the field they should be assembled and tested at a convenient bench top location. This will make it easier to verify / change settings and check operation when both units are visible at the same time.

It is also a chance to become familiar with the system if this is the first time using the Suprex system. It is much more difficult to set up and test the units when they are several thousand feet apart.

Both units will need to be connected via a network crossover cable or the same network switch and each will need to be powered by a suitable power supply. For testing purposes, the units can share the same power supply.

## Basic Bench Test:

*During initial setup, refer to the Run / Configuration mode settings (pgs 7-9).*

1. Connect a suitable power supply to both units. Each unit should be provided with 8 - 16 Volts dc and approx 300mA.
2. If a crossover cable is being used for the bench test, connect it to both units and skip to step 3. If connecting the units to a switch, follow the steps below.
  - a. Connect the switch to a computer. Connect the Central and Remote units to the switch with network cables.
  - b. Disable the wireless network adaptor on the computer. Make sure the wired network adaptor is enabled. Change the computer's static IP address to 192.168.49.100 (see pgs. 12 - 14).
3. Apply power. After about a 5-10 second delay the Diagnostic LED on each unit should flash green. The supervision relay (Relay 3) activates when the units are communicating. Note: Supervision relay is disabled by default (see pgs. 7-9).
4. Touch a jumper wire from the ground connection to the Relay 1 input on the Central unit. Relay 1 on the Remote unit should activate with an audible click.
5. Units are shipped from the factory set for the Wiegand data format. If a different format is required, set the DIP switch to the required reader and panel format (see pgs. 7-9).
6. If a reader & panel are accessible, connect the reader to the Remote unit, and the Central unit to the panel to verify card reads are accepted by the access control system. If troubleshooting is necessary, it is easier with units in close proximity.
7. Once these steps are completed, the units are ready to be configured with their final network settings and installed at their permanent locations (see pgs. 15 - 20).

## Final Field Installation Checklist:

- The Central unit and access control panel share a common ground.
- The Remote unit and the reader share a common ground.
- The Central and Remote units have been configured to be compatible with the network.
- The Central unit can "see" the Remote unit on the network.
- The Remote unit can "see" the Central unit on the network.

# Cypress Suprex® TCP/IP Series - Indicators and Operating Modes

## LED DIAGNOSTIC INDICATOR

The LED Diagnostic indicator provides information on the operational status of the unit.

If the units are not communicating, viewing the diagnostic indicator LEDs may help to determine the nature of the problem (see Troubleshooting, pg. 24).

- **If Central or Remote diagnostic LED is not illuminated:**  
If the LED(s) are not illuminated on the unit(s), the unit is not powered or there is an electrical problem. When power is properly applied, the Diagnostic LEDs will be illuminated to show a status below.
- **If the Central and Remote unit LEDs are flashing green:**  
When power is properly applied, and there is communication between the Central and the Remote, the Central and Remote unit LEDs will flash green after every polling cycle. The speed will depend on how many expansion units are connected (about 1 flash per second with 7 EXPs).
- **If the Central or Remote unit LED alternates between green/red:**  
There is no communication with the partner unit.
- **If the Central or Remote unit LEDs are solid green:**
  - **If the unit is in Configuration Mode**, then the settings have been successfully applied and it is safe to power cycle the unit and switch back to Run Mode.
  - **If the unit is in Run Mode**, one of the EXP-2000 units is not communicating properly. Check that all connected EXP-2000 units are powered and properly connected, or, if no EXP units are connected, be sure the SPX-7200 is not set to use EXP expansion units (see Configuration Mode, below).

## OPERATING MODES

Suprex products have 3 operating modes: Run Mode, Configuration Mode, and Test Mode.

- **Run Mode:** The units are factory-shipped in Run Mode.  
Run Mode allows changing of common settings while Suprex units are in use. Some factory-set defaults may be changed in Run Mode, including the following default settings.

Run Mode default settings:

- Units are set to operate as 1 Remote and 1 Central unit
- Supervision relay is disabled
- Pullup resistors are disabled
- Number of EXP Expansion Pairs is set to 0

- **Configuration Mode:** Switch to Configuration Mode to change the link type and interface type.

Configuration Mode default settings:

- Default interface type is Wiegand
- Link type is pre-set based on the Suprex model

- **Test Mode:** Test Mode is used for troubleshooting the reader/panel connection to the Remote/Central unit. In Test Mode, DIP switches 3-8 operate as if in Run Mode. Either a single unit or both units can be set to Test Mode; the Remote and Central units retain all their normal functionality in addition to the following functions:
  - In Test Mode, the Central unit outputs a test card read in the selected interface type every few seconds
  - In Test Mode, the Remote unit briefly triggers Relay 2 when detecting data of the selected interface type

# Cypress Suprex® TCP/IP Series - Common Configuration and Run Mode Settings

## Configuration Mode settings

Standard Wiegand interface is the default setting. To use with non-Wiegand interface:

- a) Power off both Suprex units.
- b) Turn on DIP switch 1 on both units.
- c) Set DIP switches as described below for appropriate interface:

<b>Default:</b> Standard Wiegand	Turn on DIP switch 8 on both units
Keypad (Wiegand/No Filter)	Turn on DIP switch 7 on both units
F/2F (Unsupervised)	Turn on DIP switches 6, 7, 8 on both units
Strobed Rising Edge (MR-5)	Turn on DIP switches 7 and 8 on both units
Strobed Rising Edge (Dorado 644)	Turn on DIP switch 6 on both units
Strobed Rising (MagTek)	Turn on DIP switches 6 and 8 on both units
Strobed Falling Edge	Turn on DIP switches 6 and 7 on both units

- d) Power on both Suprex units. Status LED should be solid green.
- e) Power off both Suprex units; return DIP switch 1 to **off** position on both units to select Run Mode settings. **When switching to Run Mode, always reselect Run Mode settings.**

## Run Mode settings

Select Run Mode settings as described below, then power on both Suprex units to begin operating in Run Mode.

Central / Remote Select	Turn DIP switch 3 <b>on</b> for Central Mode / turn <b>off</b> for Remote Mode
Remote Digital/Analog Relay Select	Turn Remote unit's DIP switch 2 <b>on</b> for digital input / <b>off</b> for analog input
Supervision Relay (Relay 3, Central unit)	Turn Central unit's DIP switch 4 on for supervision relay / off for normal relay
Supervision Relay (Relay 1, Remote unit)	Turn Remote unit's DIP switch 4 <b>on</b> for supervision relay / <b>off</b> for normal relay
Pullup Resistor Select	Turn <b>on</b> DIP switch 5 to enable pullup resistors / <b>off</b> to disable [applicable units]
EXP Select (for <b>no</b> EXP)	Turn <b>off</b> DIP switches, 6, 7, and 8 on both units
EXP Select (for <b>1</b> EXP)	Turn <b>on</b> DIP switch 8 on both units
EXP Select (for <b>2</b> EXPs)	Turn <b>on</b> DIP switch 7 on both units
EXP Select (for <b>3-7</b> EXPs)	See pg. 9

## Test Mode setting

See page 24 to troubleshoot using Test Mode.

Test Mode Select	Turn DIP switch 2 <b>on</b> for Remote &/or Central
------------------	---

# Cypress Suprex® TCP/IP Series - SPX-7200 DIP Switch Map

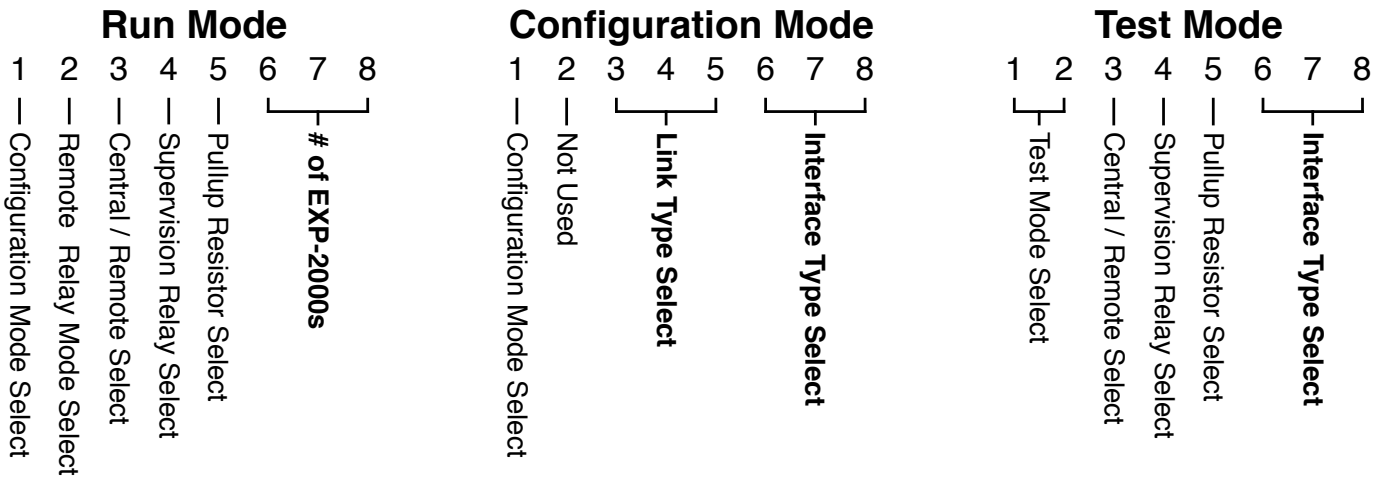

Configuration Mode Select - ON = Configuration Mode - OFF = Run Mode

Remote Relay Mode Select - ON = Digital Input - OFF = Analog Input

Central / Remote Select - ON = Central - OFF = Remote

Supervision Relay Select - ON = Enable Supervision Relay - OFF = Disable Supervision Relay

Pullup Resistor Select - ON = Enable Pullup Resistor - OFF = Disable Pullup Resistor

Test Mode Select - DIP Switches 1 & 2 ON = Test Mode

# of EXP-2000 Pairs			Link Type Select			Interface Type Select		
6	7	8 - (Run Mode)	3	4	5 - (Config Mode)	6	7	8 - (Config and Test Mode)
0	0	0 - None	0	0	0 - No Change	0	0	0 - No Change
0	0	1 - 1 Pair	0	1	1 - Ethernet	0	0	1 - Wiegand
0	1	0 - 2 Pairs				0	1	0 - Wiegand No Filter
0	1	1 - 3 Pairs				0	1	1 - Strobed Rising (MR5)
1	0	0 - 4 Pairs				1	0	0 - Strobed Rising (Dorado 644)
1	0	1 - 5 Pairs				1	0	1 - Strobed Rising (Mag-Tek)
1	1	0 - 6 Pairs				1	1	0 - Strobed Falling
1	1	1 - 7 Pairs	NOTE - 0 = OFF - 1 = ON			1	1	1 - Unsupervised F/2F

- The DIP Switch selections in Run Mode and Test Mode are ACTIVE, meaning that they can be changed on the fly without power cycling the unit.

- The DIP Switch selections in Configuration Mode are NOT ACTIVE. This means to set Configuration Mode setting the unit will need to be powered off, turn DIP 1 on and other Configuration DIP Switches as needed, power the unit on and the Status LED will be solid green. The solid green LED means the settings have been set. Power the unit off and return the DIP Switches to the Run Mode positions.

- When using the Remote unit with digital relay inputs the relays are controlled by the "not used" pins on the 10 pin header. Connect the outside "not used" pin to "Ground" to trigger Relay 3. Connect the inside "not used" pin to "Ground" to trigger Relay 4.

- When using the Remote unit with analog relay inputs the relays are controlled by the "Relay 3 in" and "Relay 4 in" pins. Connect "Relay 3 in" to "Ground" to trigger Relay 3. Connect "Relay 4 in" to "Ground" to trigger Relay 4.

-The Remote Relay Mode Select (Dip Switch 2 in Run Mode) is only used on the Central unit, and has no functionality on the Remote unit.

# Cypress Suprex® TCP/IP Series - Quick Reference For Typical Connections

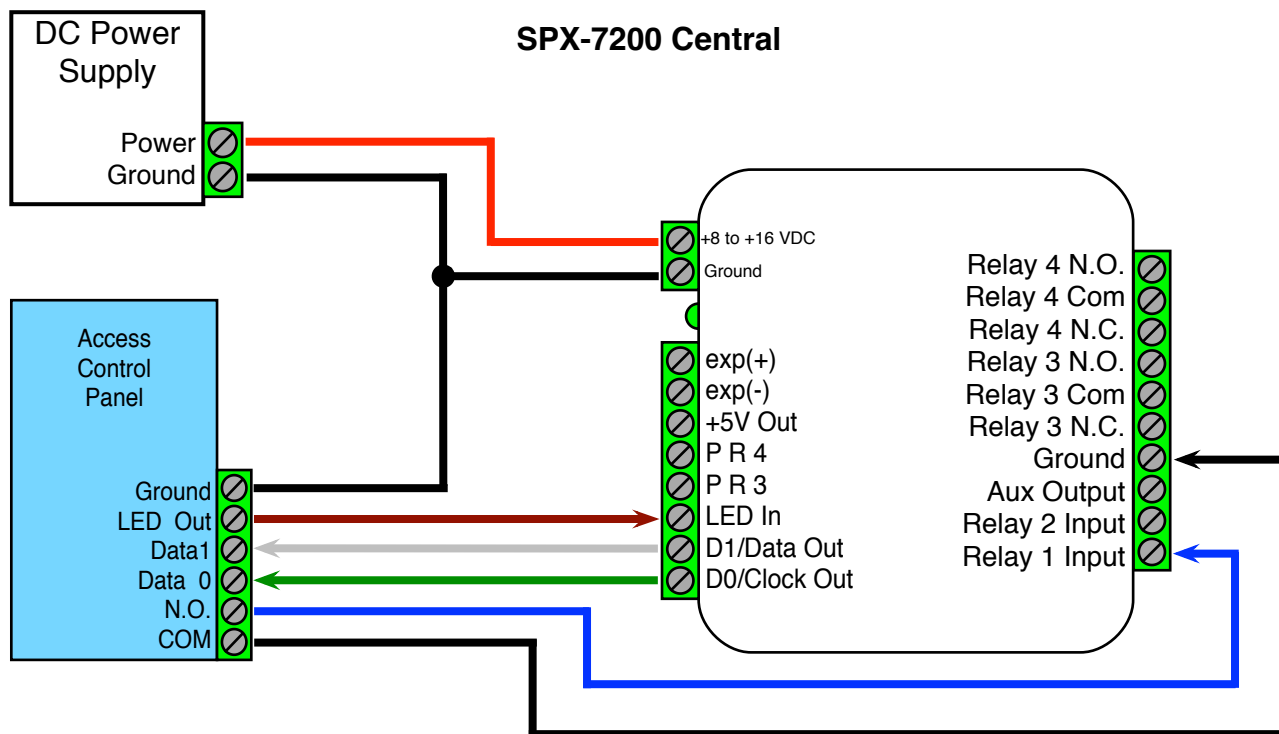

In this wiring example, the door strike follows a dry contact input from the access control panel. See page 26 for other strike control options.

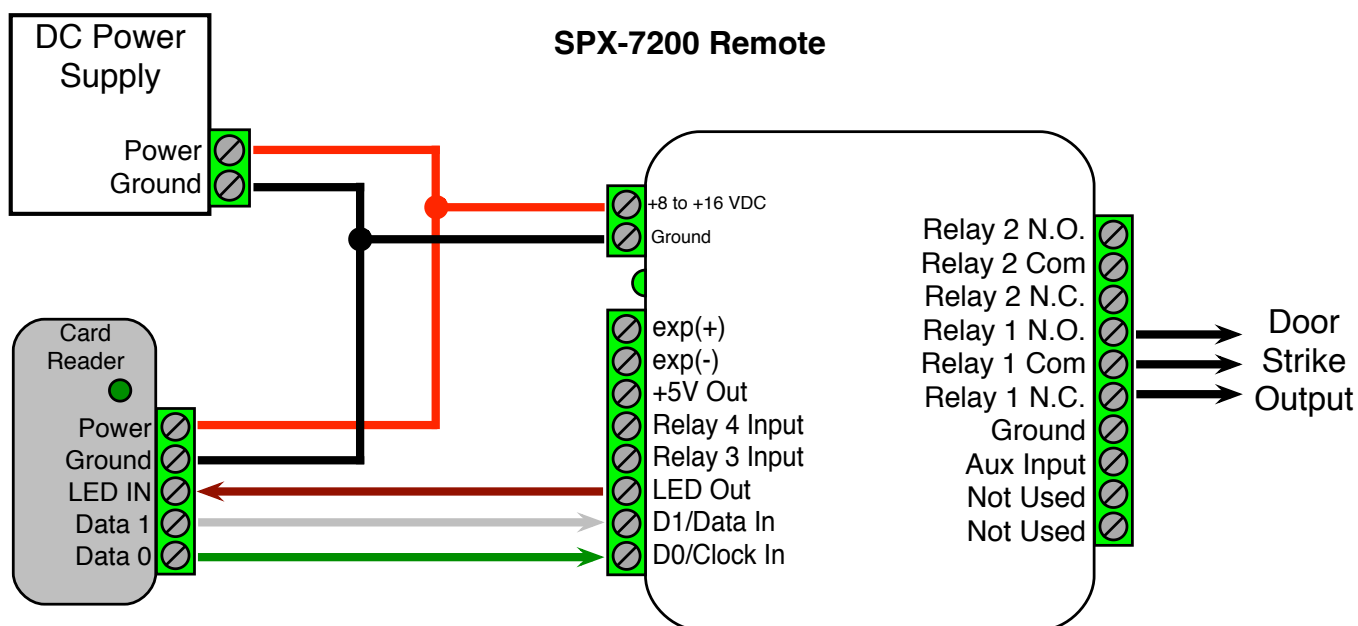

# Cypress Suprex® TCP/IP Series - SPX-7200 Network Settings

## Overview:

The following sections cover how to connect a computer to an SPX-7200 Central and/or Remote and change the network settings of the device. These sections include:

- SPX-7200 Network Settings
- SPX-7200 Enabling Telnet Client
- Changing Network Adaptor Settings in Windows
- SPX-7200 Network Settings via Web Browser
- SPX-7200 Network Settings via Telnet

There are two primary methods of connecting to the SPX-7200 Central and Remote units: connecting to the unit with a web browser, and connecting to the unit using Telnet, as outlined below.

## Factory Reset Network Settings:

If a connection to the Central or Remote unit cannot be established, the units can be factory reset to their default network settings. The factory reset is used to give the Central or Remote unit a known IP address.

1. Power Central and Remote units off.
2. Since the DIP switches are on the circuit board, it is necessary to remove the Central and Remote boards from their enclosures. To do this, remove the 4 screws from one of the end plates and remove the heat sink screw from the bottom of the unit. Slide the board out of the enclosure. When reassembling the units, it is very important to re-attach each heat sink screw to prevent damage from overheating.
3. Turn all DIP switches off on both the Central and Remote units, then set DIP switches 1, 4, 5, and 8 to on, on both units.
4. Power both units on. The Status LED should be solid green on both units. Power both units down.
5. Turn all DIP switches off on the Remote unit. For the Central unit, set only DIP switch 3 on.
6. The next time the Central or Remote units are powered on, the units will default the Network settings. The Status LED will start as solid red, then slowly blink green for about 20 seconds. Once the units are flashing between red and green, the process is complete and the units are ready to use.

## Changing the Network Adaptor Settings in Windows:

When connecting the to SPX-7200 Central or Remote unit with a computer, the computer needs to have an IP address that is compatible with the SPX-7200 units. The IP addresses need to be compatible if connecting via a web browser or if connecting with the Telnet Client. (See Changing Network Adaptor Settings in Windows pgs. 12 - 13)

## Enabling Telnet:

By default, the Telnet Client is not enabled in Windows 7, Windows 8, and Windows 10. An error message (shown below) will be displayed when attempting to connect to the SPX-7200 Central or Remote unit If the Telnet Client is not enabled. (See Enabling Telnet Client pgs. 21 - 23)

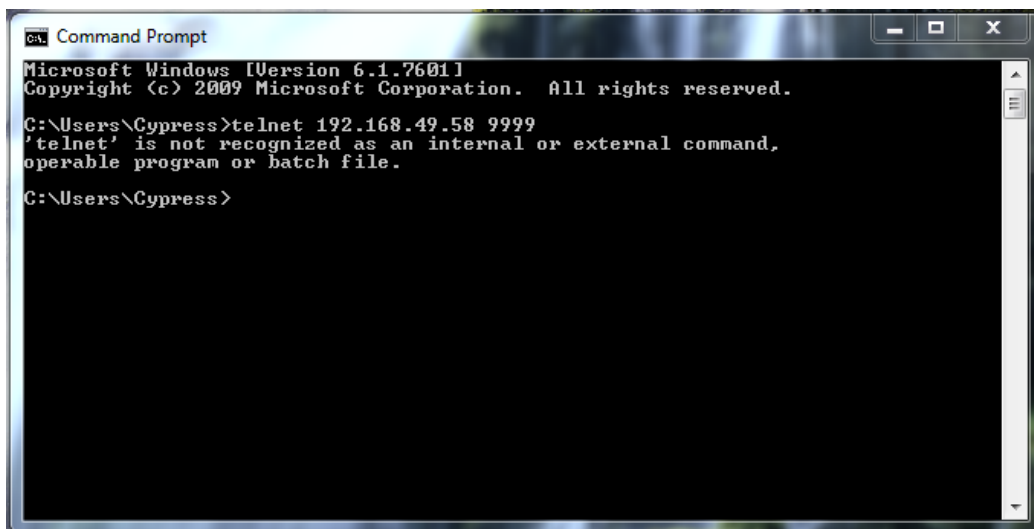

```
ca Command Prompt
Microsoft Windows [Version 6.1.7601]
Copyright (c) 2009 Microsoft Corporation. All rights reserved.

C:\Users\Cypress>telnet 192.168.49.58 9999
'telnet' is not recognized as an internal or external command,
operable program or batch file.

C:\Users\Cypress>
```

# Cypress Suprex® TCP/IP Series - Changing Network Adaptor Settings in Windows

This section covers how to change the Network Adaptor settings on Windows 7, Windows 8, and Windows 10. Regardless of the method used, it is necessary to change the network adaptor settings when connecting SPX-7200 Central or Remote units to the computer.

The screenshots below show Windows 7. The steps to get to the Network and Sharing Center vary slightly for each version (see below). However, once at the Network and Sharing Center, the steps are the same for all 3 versions.

## Step 1

Go to Network and Sharing Center.

- Windows 7: Click the Start Button. Click *Control Panel* on the right. Click *Network and Sharing Center*.
- Windows 8: Right-click the Start Button. Click *Control Panel*. Click *Network and Sharing Center*.
- Windows 10: Right-click the Start Button. Click *Control Panel*. Click *Network and Sharing Center*.

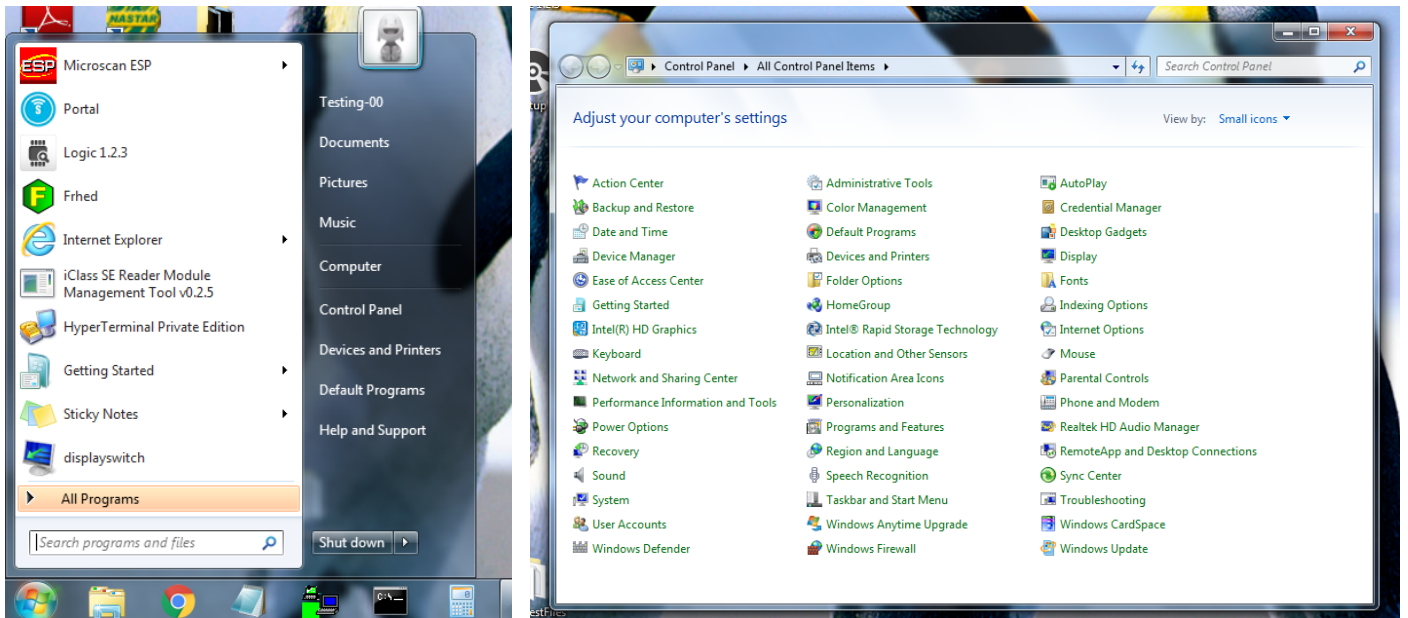

## Step 2

Click *Change adaptor settings*.

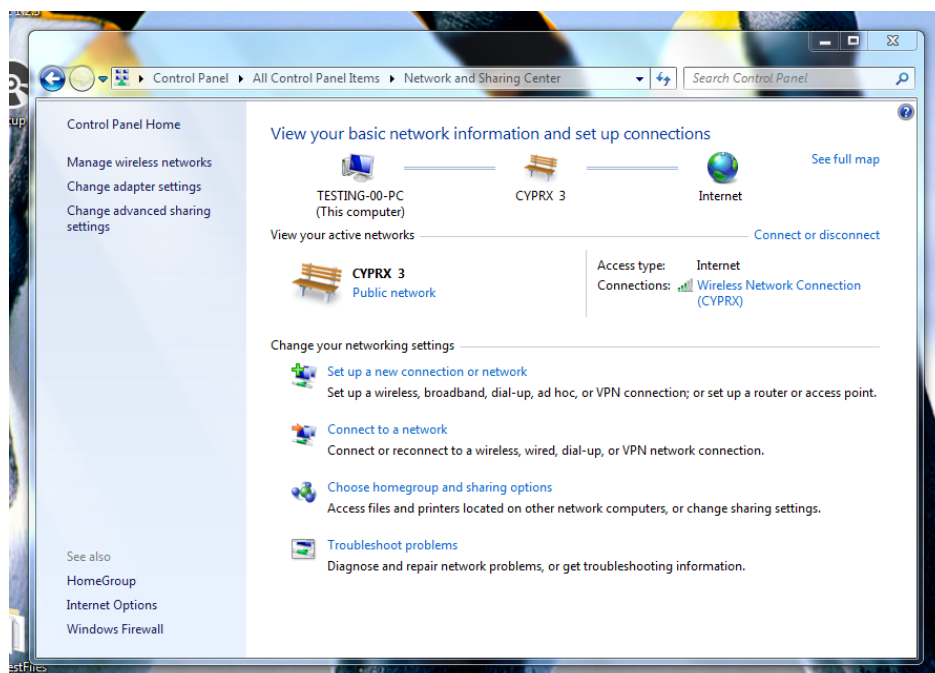

# Cypress Suprex® TCP/IP Series - Changing Network Adaptor Settings in Windows (cont.)

## Step 3

Disable the Wireless Network Connection, if one is present. Right-click the *Wireless Network Connection* box and select *disable*.

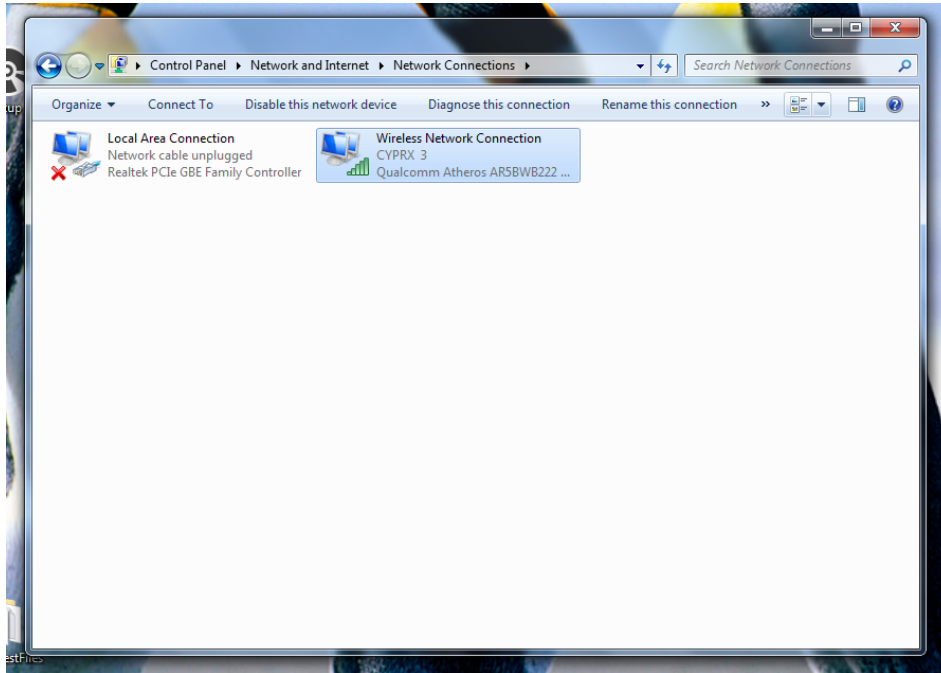

## Step 4

Right-click *Local Area Connection* and select *Properties*.

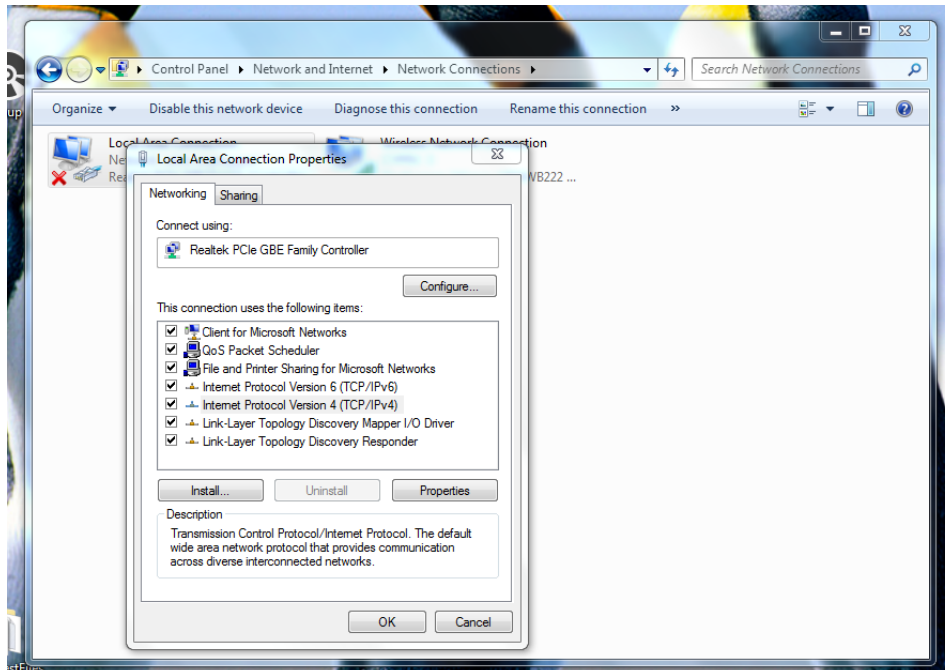

# Cypress Suprex® TCP/IP Series - Changing Network Adaptor Settings in Windows (cont.)

## Step 5

Click *Internet Protocol Version 4 (TCP/IPv4)* in the list. Click *Properties*, below the list.

## Step 6

Select *Use the following IP address*:

## Step 7

If the Central or Remote unit has not had its network settings changed, use the IP address and Subnet Mask in Step 8. Otherwise use an IP address and Subnet Mask that is compatible with how the Central or Remote unit is configured.

## Step 8

Enter 192.168.49.100 as the IP Address. Enter 255.255.255.0 as the Subnet Mask.

## Step 9

Click *OK* at the bottom of the window.

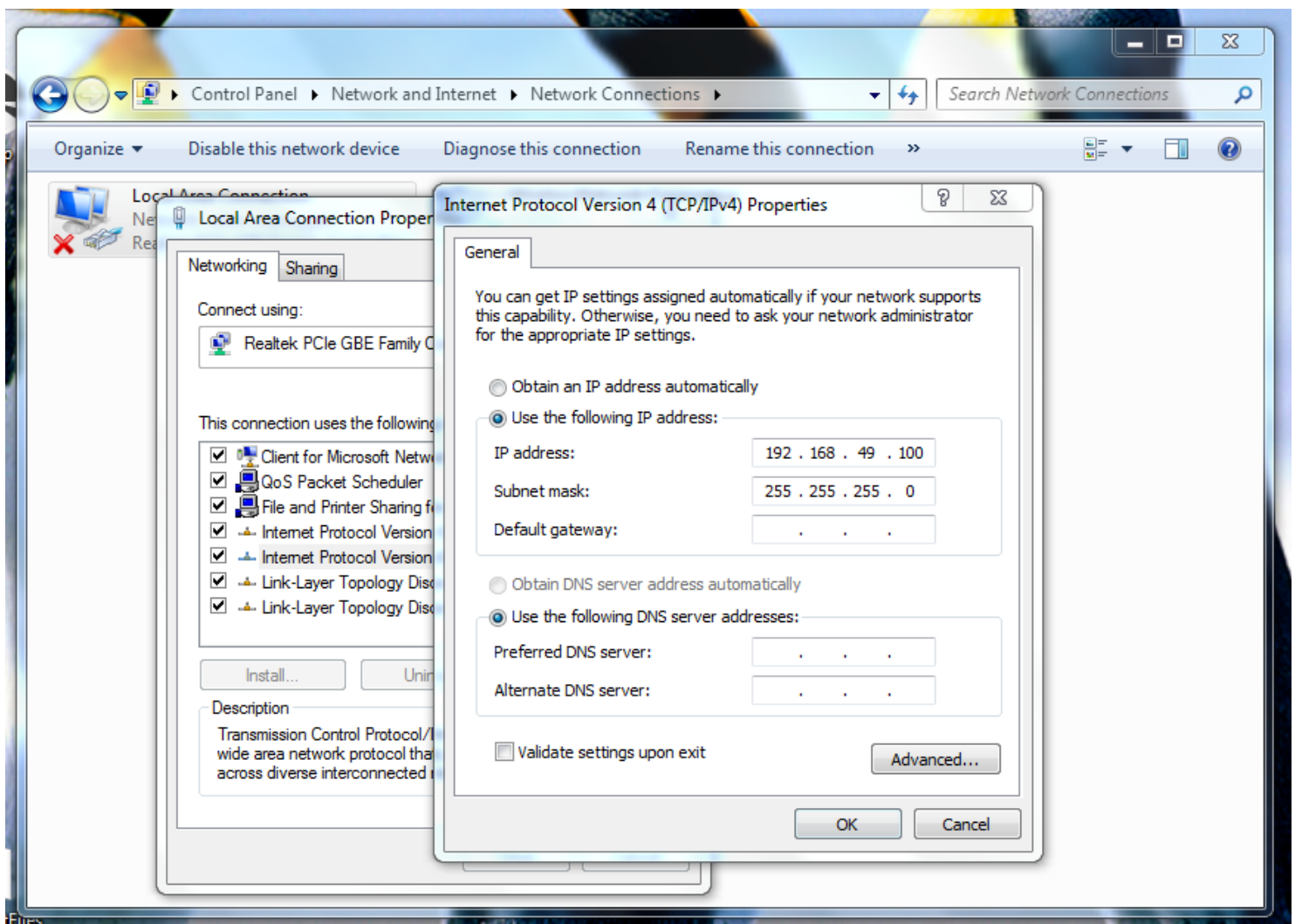

# Cypress Suprex® TCP/IP Series - SPX-7200 Network Settings via Web Browser

## Connecting to the SPX-7200 via a Web Browser:

### Step 1

Connect the SPX-7200 Central or Remote unit to a computer with a network cable. Make sure the computer's network adaptor settings are set to be compatible with the SPX-7200. If necessary, follow the steps in the **Changing Network Adaptor Settings in Windows** section (see pgs. 12-14). The examples in this guide use Google Chrome.

### Step 2

Open a web browser and enter the IP address of the Central or Remote unit into the address bar, then press enter. (Central Default IP: 192.168.49.58, Remote Default IP: 192.168.49.59)

### Step 3

A window should appear prompting the user for a user name and password. Do not enter a user name or a password. Click *Log In*.

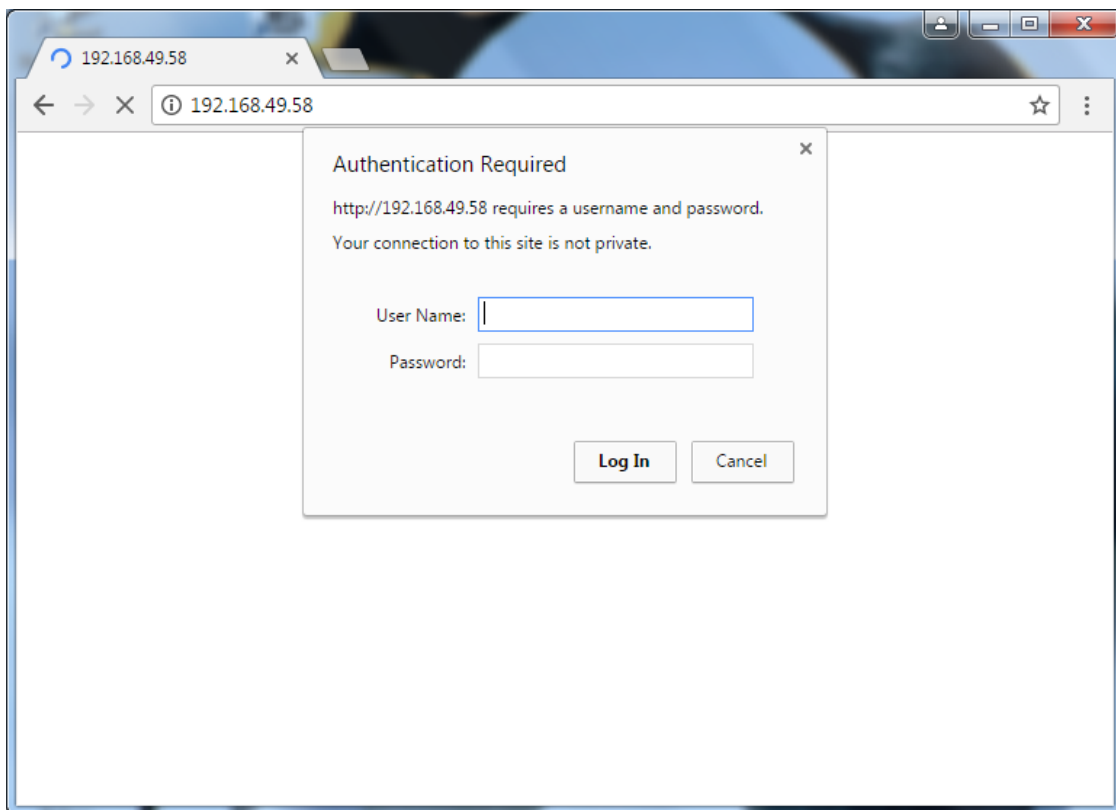

# Cypress Suprex® TCP/IP Series - SPX-7200 Network Settings via Web Browser

## Step 4

A menu titled Device Status will appear. Click *Network* on the left.

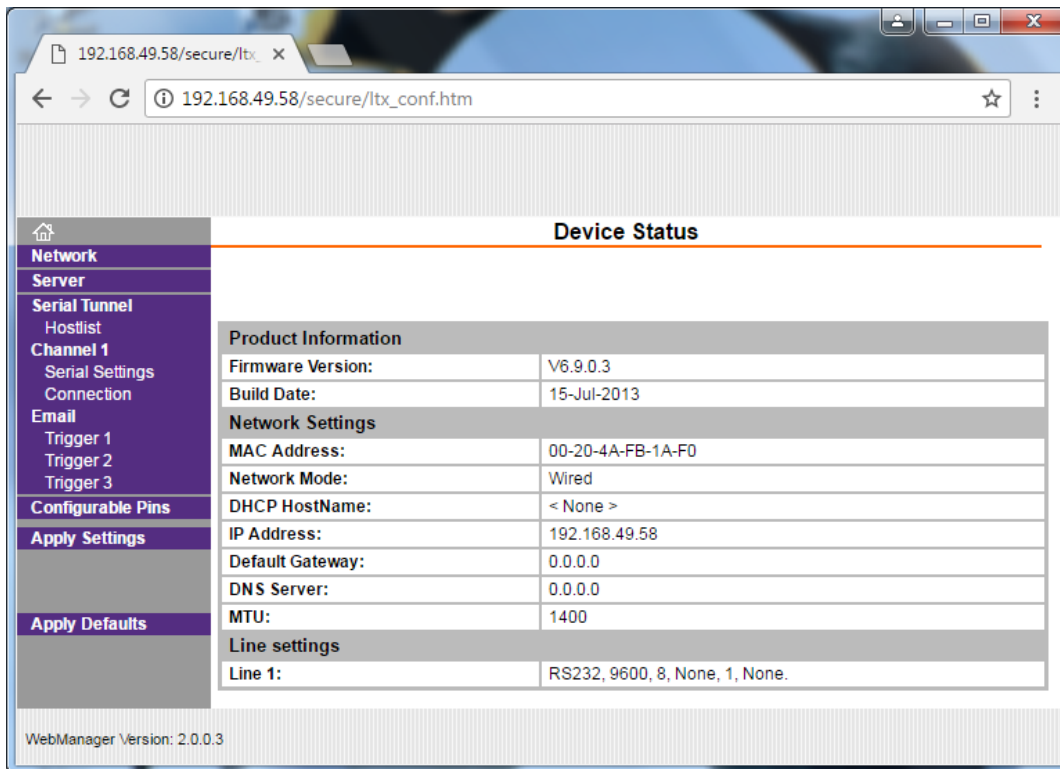

The screenshot shows a web browser window displaying the 'Device Status' page. The address bar shows '192.168.49.58/secure/ltx\_conf.htm'. The left sidebar contains a navigation menu with 'Network' highlighted. The main content area displays the following information:

Product Information	
Firmware Version:	V6.9.0.3
Build Date:	15-Jul-2013

Network Settings	
MAC Address:	00-20-4A-FB-1A-F0
Network Mode:	Wired
DHCP HostName:	< None >
IP Address:	192.168.49.58
Default Gateway:	0.0.0.0
DNS Server:	0.0.0.0
MTU:	1400

Line settings	
Line 1:	RS232, 9600, 8, None, 1, None.

WebManager Version: 2.0.0.3

## Step 5

Enter the desired IP address of the unit. Enter other information if necessary. Scroll to the bottom of the page. Click *OK*. "Done!" should appear next to the button.

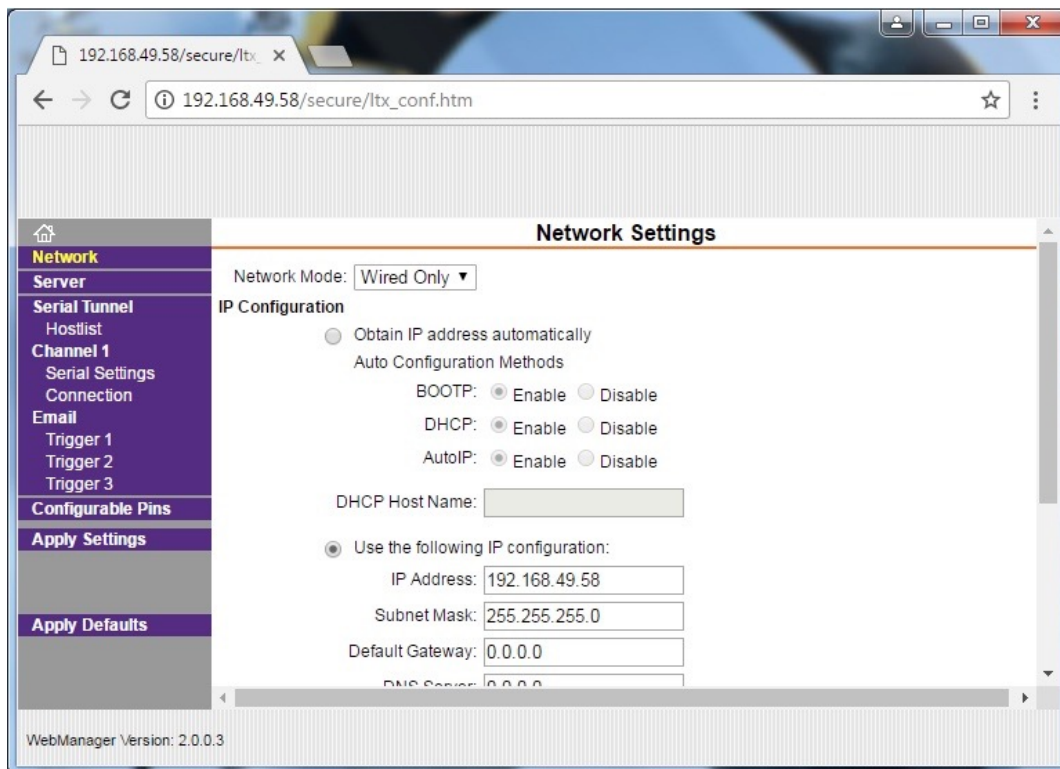

The screenshot shows a web browser window displaying the 'Network Settings' page. The address bar shows '192.168.49.58/secure/ltx\_conf.htm'. The left sidebar contains a navigation menu with 'Network' highlighted. The main content area displays the following configuration options:

Network Mode:

IP Configuration

Obtain IP address automatically

Auto Configuration Methods

BOOTP:  Enable  Disable

DHCP:  Enable  Disable

AutoIP:  Enable  Disable

DHCP Host Name:

Use the following IP configuration:

IP Address:

Subnet Mask:

Default Gateway:

DNS Server:

WebManager Version: 2.0.0.3

# Cypress Suprex® TCP/IP Series - SPX-7200 Network Settings via Web Browser (cont.)

## Step 6

On the left, click *Connections*. Locate Remote Host under Endpoint Configuration. Enter the IP address of the partner unit. If connected to the Central unit, enter the Remote unit's IP address. If connected to the Remote unit, enter the Central unit's IP address. When finished, scroll down to the bottom of the page and click *OK*. "Done!" should appear next to the OK button.

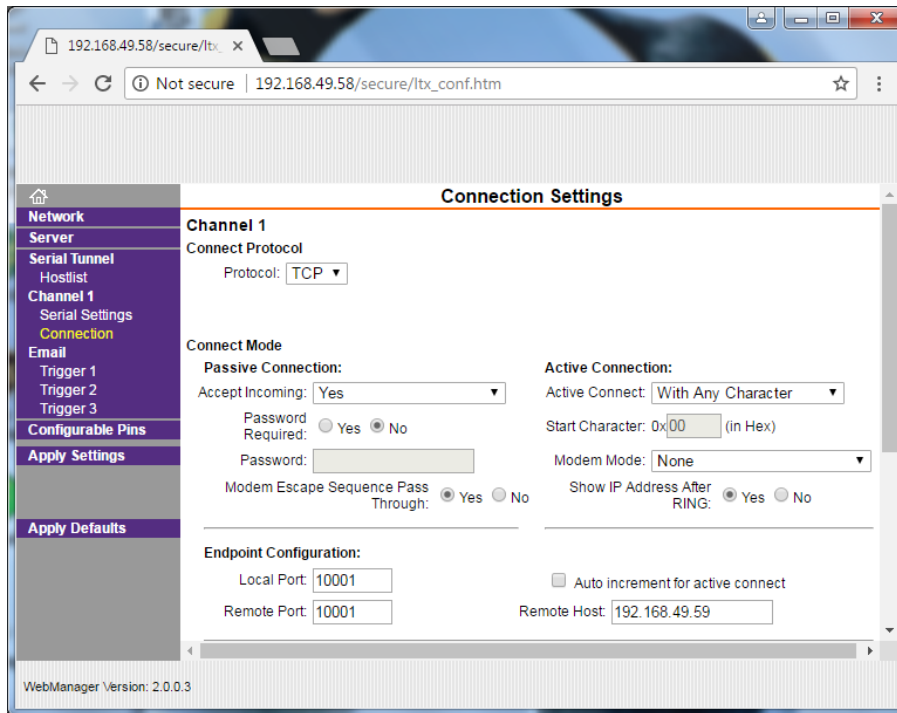

## Step 7

After all the Network Settings have been entered, click *Apply Settings* on the left side of the window. The main body of the window will disappear and "ERROR 404" will appear at the top.

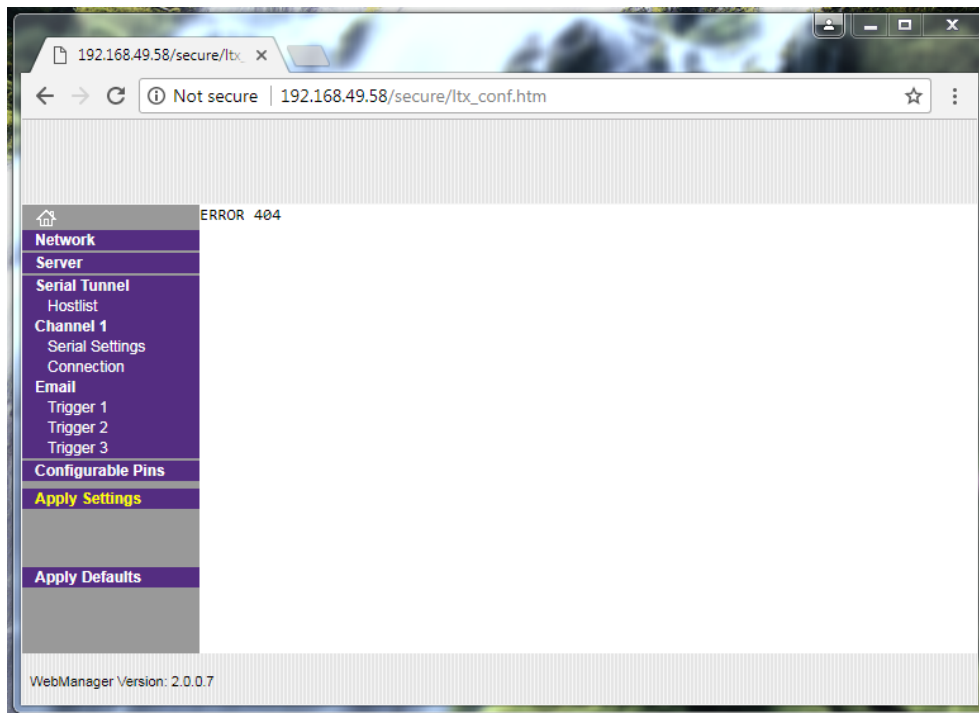

## Step 8

The process of changing the SPX-7200 network settings is now complete. The web browser can be closed and the SPX-7200 can be disconnected from the computer.

# Cypress Suprex® TCP/IP Series - SPX-7200 Network Settings via Telnet

## Connecting to the SPX-7200 via Telnet:

### Step 1

Connect the SPX-7200 Central or Remote unit to a computer with a network cable. Make sure the computer's network adaptor settings are set to be compatible with the SPX-7200. If necessary, follow the steps in the **Changing Network Adaptor Settings in Windows** section (see pgs. 12-14).

### Step 2

To open Command Prompt, press the Windows Key + R and enter "cmd". Command Prompt window should appear.

### Step 3

To connect to the SPX-7200 Central, type "telnet 192.168.49.58 9999" and press enter. To connect to the SPX-7200 Remote, type "telnet 192.168.49.59 9999" and press enter. This example uses the default IP addresses, if the Central and Remote units are not set to the default IP addresses, use the actual IP address in their place. If the message "telnet is not recognized as an internal or external command, operable program or batch file" appears, then the Telnet Client is not installed. (See Enabling Telnet pgs. 21 - 23)

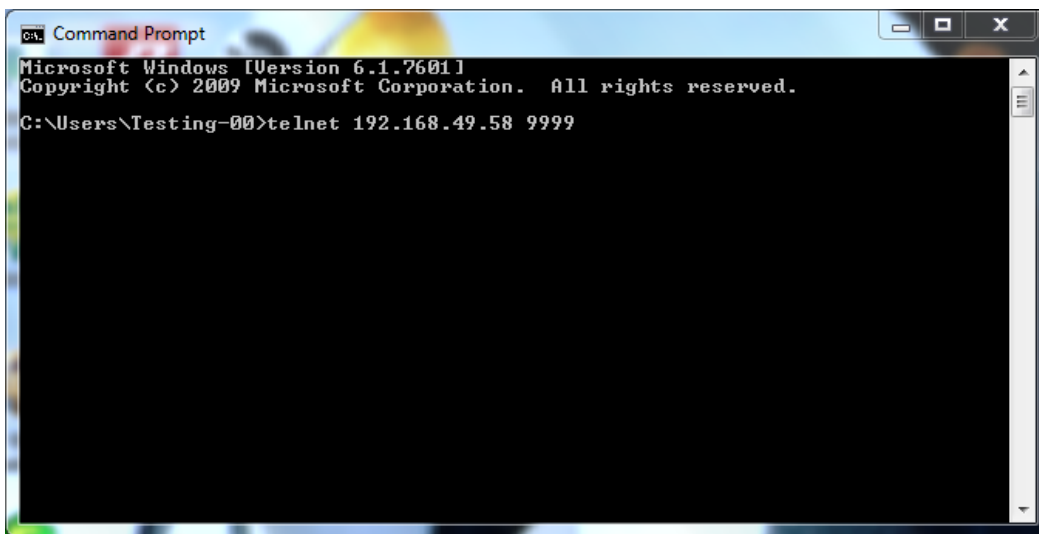

```
ca. Command Prompt
Microsoft Windows [Version 6.1.7601]
Copyright (c) 2009 Microsoft Corporation. All rights reserved.

C:\Users\Testing-00>telnet 192.168.49.58 9999
```

### Step 4

The window should change and show some information about the unit, including the MAC address, along with "Press Enter for Setup Mode".

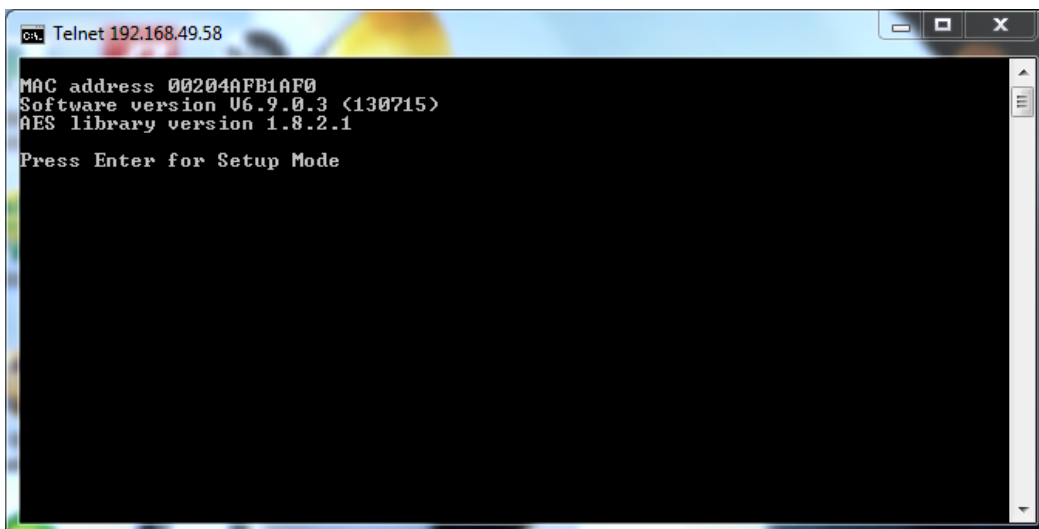

```
ca. Telnet 192.168.49.58

MAC address 00204AFB1AF0
Software version U6.9.0.3 <130715>
AES library version 1.8.2.1

Press Enter for Setup Mode
```

# Cypress Suprex® TCP/IP Series - SPX-7200 Network Settings via Telnet (cont.)

## Step 5

Press enter again. The Change Setup menu will appear. To change the unit's IP address, press 0 to enter the Server menu.

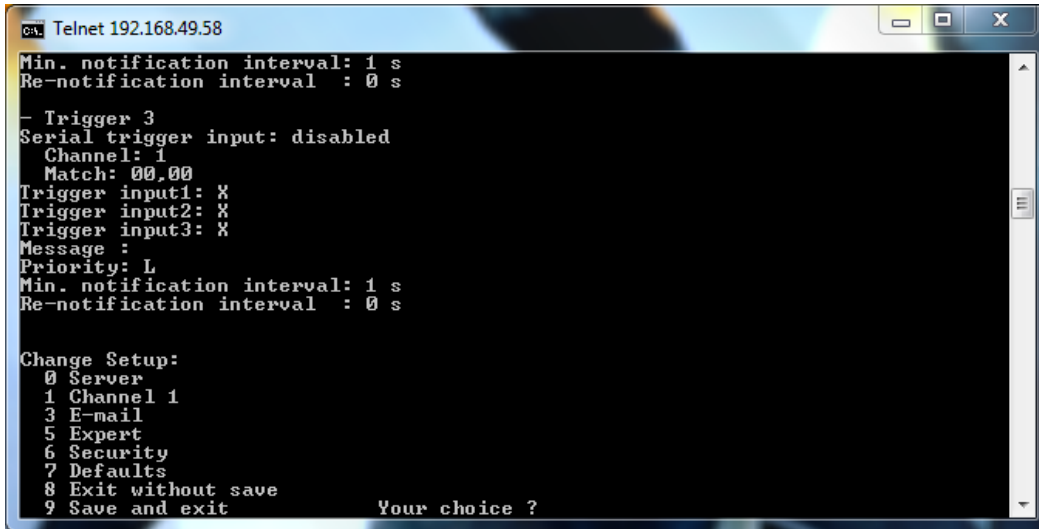

```
ca. Telnet 192.168.49.58
Min. notification interval: 1 s
Re-notification interval : 0 s

- Trigger 3
Serial trigger input: disabled
  Channel: 1
  Match: 00.00
Trigger input1: X
Trigger input2: X
Trigger input3: X
Message :
Priority: L
Min. notification interval: 1 s
Re-notification interval : 0 s

Change Setup:
 0 Server
 1 Channel 1
 3 E-mail
 5 Expert
 6 Security
 7 Defaults
 8 Exit without save
 9 Save and exit          Your choice ?
```

## Step 6

The first prompt is the IP address. If a new IP address is required, enter the IP new IP address and press enter. If a new IP address is not required, simply press enter for each section of the IP address and the current IP address will auto fill in each section. Other relevant prompts include setting the gateway IP address and setting the DNS server UP address. Change these as needed. Once all of the prompts have been answered, the user will be taken back tot he Change Setup menu.

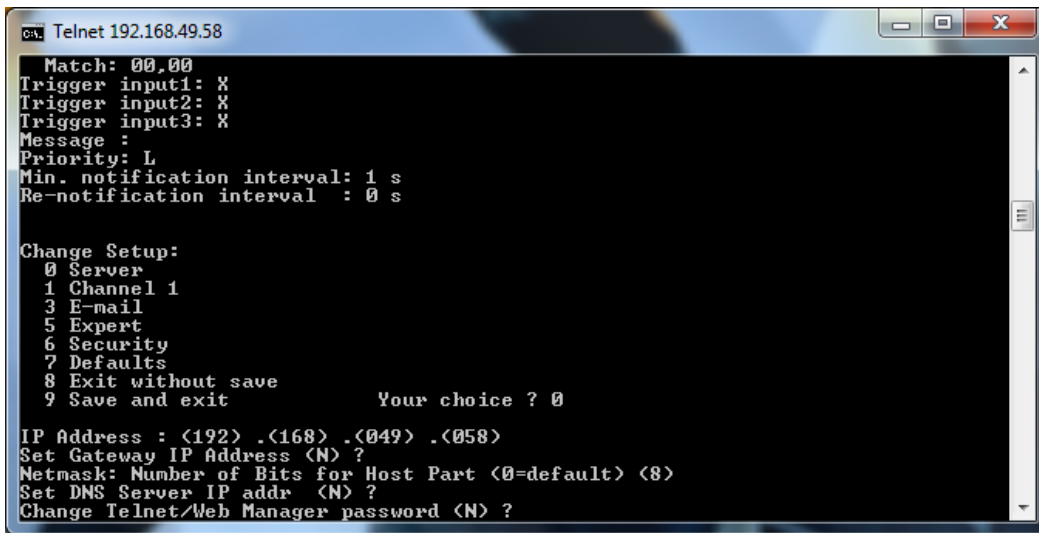

```
ca. Telnet 192.168.49.58
Match: 00.00
Trigger input1: X
Trigger input2: X
Trigger input3: X
Message :
Priority: L
Min. notification interval: 1 s
Re-notification interval : 0 s

Change Setup:
 0 Server
 1 Channel 1
 3 E-mail
 5 Expert
 6 Security
 7 Defaults
 8 Exit without save
 9 Save and exit          Your choice ? 0

IP Address : <(192) .<(168) .<(049) .<(058)
Set Gateway IP Address <(N) ?
Netmask: Number of Bits for Host Part <(0=default) <(8)
Set DNS Server IP addr <(N) ?
Change Telnet/Web Manager password <(N) ?
```

# Cypress Suprex® TCP/IP Series - SPX-7200 Network Settings via Telnet (cont.)

## Step 7

Press 1 to enter the Channel 1 menu. Press the enter key 8 times to get to Remote IP Address. Enter the IP address of the partner unit. If connected to the Central unit, enter the IP address of the Remote unit. If connected to the Remote unit, enter the IP address of the Central unit. Once the correct IP address has been entered, press the enter key to get through all of the prompts and back to the Change Setup menu.

```
ca. Telnet 192.168.49.58
Change Setup:
0 Server
1 Channel 1
3 E-mail
5 Expert
6 Security
7 Defaults
8 Exit without save
9 Save and exit          Your choice ? 1

Baudrate (9600) ?
I/F Mode (4C) ?
Flow (00) ?
Port No (10001) ?
ConnectMode (C1) ?
Send '+++' in Modem Mode (Y) ?
Show IP addr after 'RING' (Y) ?
Auto increment source port (N) ?
Remote IP Address : (192).(168).(049).(059) ?
Remote Port (10001) ?
DisConnMode (00) ?
FlushMode (00) ?
DisConnTime (00:00) ?:
SendChar 1 (00) ?
SendChar 2 (00) ?
```

## Step 8

When all of the necessary parameters have been entered and at the Change Setup menu, press 9 “Save and Exit” to save the parameters and disconnect from the Central or Remote. “Parameters stored ...” will appear.

```
ca. Command Prompt
Trigger input1: X
Trigger input2: X
Trigger input3: X
Message :
Priority: L
Min. notification interval: 1 s
Re-notification interval : 0 s

Change Setup:
0 Server
1 Channel 1
3 E-mail
5 Expert
6 Security
7 Defaults
8 Exit without save
9 Save and exit          Your choice ? 9

Parameters stored ...

Connection to host lost.
C:\Users\Cypress>
```

# Cypress Suprex® TCP/IP Series - Enabling Telnet Client

## Enabling Telnet:

If the error message shown in the image below appears when attempting to connect to the SPX-7200 Central or Remote unit, the Telnet Client is not enabled. This section covers how to enable the Telnet Client.

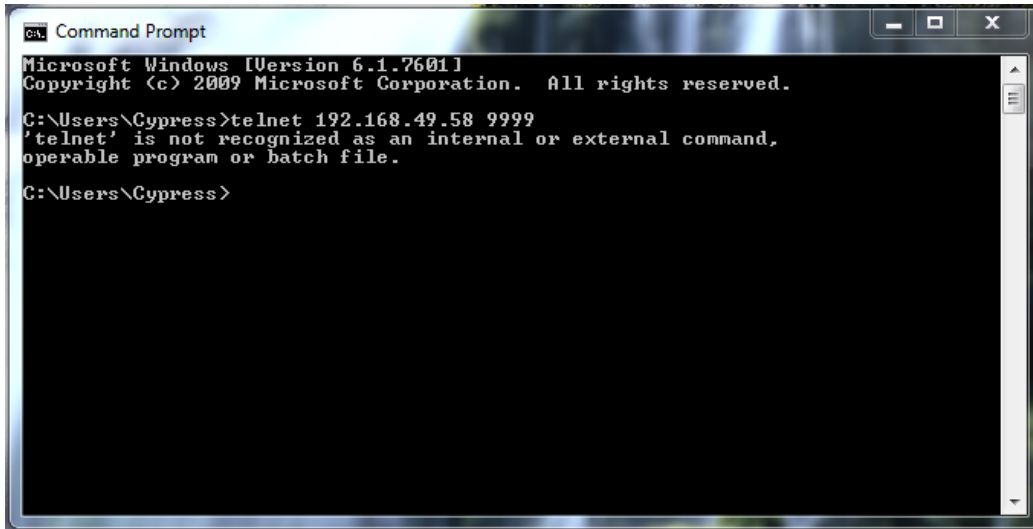

## Step 1

Get to Control Panel.

- Windows 7: Click on the Start Button. Click Control Panel on the right.
- Windows 8: Right-click on the Start Button. Click Control Panel.
- Windows 10: Right-click on the Start Button. Click Control Panel.

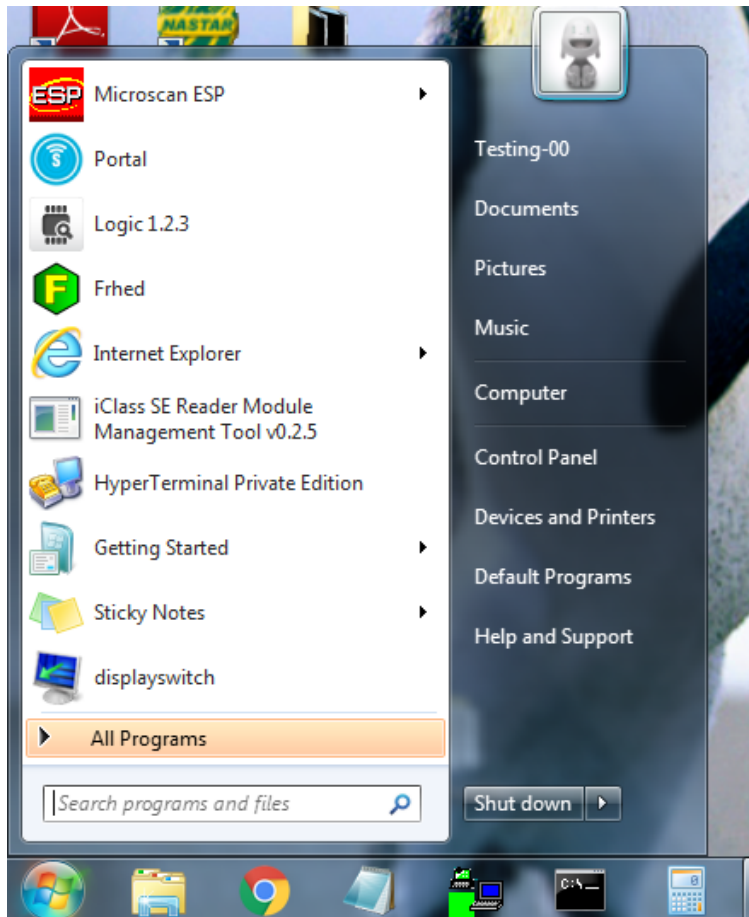

# Cypress Suprex® TCP/IP Series - Enabling Telnet Client (cont.)

## Step 2

Click on Programs and Features in the Control Panel window.



## Step 3

Click "Turn Windows Features on or off" on the left side of the window.

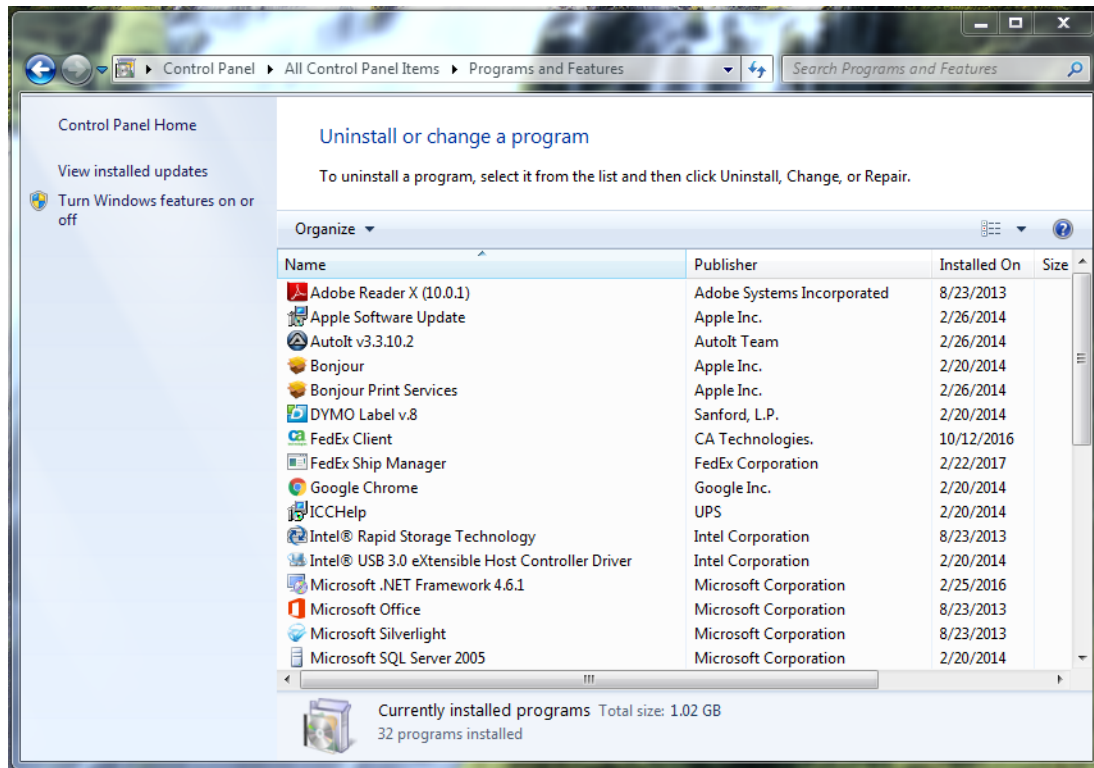

## Cypress Suprex® TCP/IP Series - Enabling Telnet Client (cont.)

### Step 4

A new window, titled “Windows Features”, will appear. Wait for the list to be populated, then scroll down to an item called “Telnet Client”. Check the check box next to Telnet Client.

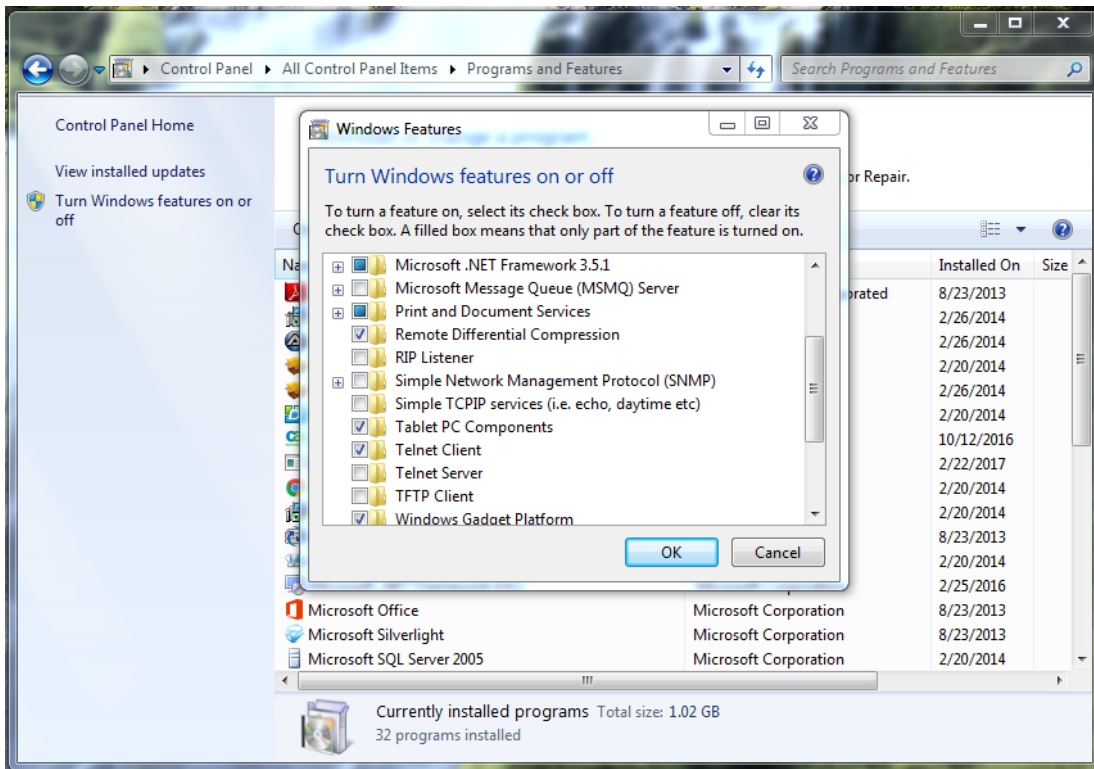

### Step 5

Click the OK button at the bottom of the window. A progress window will appear and the process will generally take about 30 seconds to complete. The Telnet Client is now enabled and connecting to the SPX-7200 Central or Remote unit can with the Telnet Client can continue.

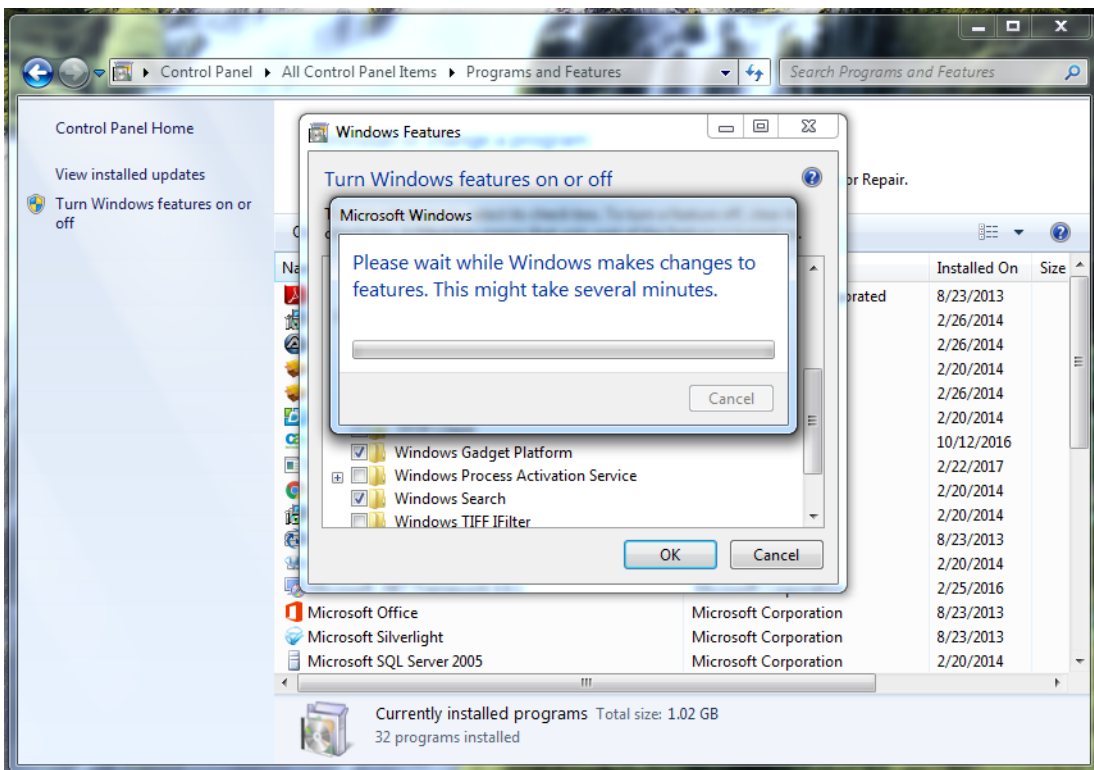

# Cypress Suprex® TCP/IP Series - Troubleshooting

## No Communication

When the Central and/or Remote unit is not communicating with its partner, the status LED will flash green/red. To troubleshoot communication issues, check the following:

- **Power:**
  - Both units must be powered.
  - Ensure proper power requirements are met: Unregulated Input 8 to 16Vdc @ 300mA max.
- **Installation:**
  - The Central and Remote units must be able to see each other on the network. To test this, ping the Remote units IP address from the Central's network location or vice versa. If there is no response from the unit being pinged, the two network locations are not connected and are not suitable for use with the SPX-7200.
  - In some instances, managed network switches can block the communication of the SPX-7200 units. Either disable the managed functionality of the switch, or create an exception for the SPX-7200 units.
  - Ensure the Remote unit's IP address is set as the Remote Host in the Central unit.
  - Ensure the Central unit's IP address is set as the Remote Host in the Central unit.
  - Ensure all of the IP settings are compatible with the network; i.e. IP address, Subnet Mask, Default Gateway, and DNS Server.
  - If connecting the units directly to each other, make sure an crossover cable is used.
- **Configuration:**
  - Ensure both Suprex units are set to the correct link type (see Configuration Mode, pgs. 7-9).
  - Ensure Suprex units' network settings are properly configured (see pgs. 15-20).

## No Data / Invalid Data

If the access control panel is not receiving valid data, check the following:

- **Basic Equipment Check:**
  - Ensure the reader and the access control panel data port are functional by directly connecting the reader to the data port and passing card data.
  - Check Suprex circuit boards for any signs of visual damage, such as burnt traces, burnt components, or browning of the PCB; these usually indicate misapplied power.
- **Wiring:**
  - Ensure there is a common ground between the Remote unit and the card reader.
  - Ensure there is a common ground between the Central unit and the access control panel.
  - Ensure Wiegand data wires are correctly connected and not reversed.
- **Configuration:**
  - Ensure both Suprex units are set to the correct interface type (see Configuration Mode, pgs. 7-9).
  - Ensure the access control panel is properly configured for the selected data format.
- **Data Voltage:** For a Wiegand connection, ensure Data 0 and Data 1 pins on Central and Remote units are at 5V relative to ground. The data pins can be as low as 4.4V before failing. If any Wiegand data pin is less than 4.4V, it is necessary to identify which device is pulling down the voltage.
  - Disconnect the Suprex from the reader/panel.
  - Maintain power on the Suprex and the reader/panel.
  - Independently measure the voltages of the Wiegand data pins of the Suprex, and of the reader/panel. If one or both devices have 4.3V or less, try enabling the pullup resistors on the Suprex by turning on DIP switch 5.
  - If internal pullup resistors do not work, try external pullup resistors (through-hole resistor 500ohms - 2Kohms). To install external pullup resistors, place one end of the through-hole resistor into the +5Vdc pin on the Suprex unit; place the other end in the low-voltage Wiegand data pin (see pg. 5).

# Cypress Suprex® TCP/IP Series - Accessory I/O - Overview

The Cypress SPX-7200 provides additional data channels to support access control hardware such as door strikes, tamper alarms, request to exit status, etc. These signals are sent to and from the Central and Remote units without the need to run additional wiring. We refer to these data channels as Accessory I/O. Accessory I/O data channels include Relay 1, Relay 2, Relay 3, Relay 4, LED, and AUX. Refer to the following pages for details of each Accessory I/O operation and connection. Below is a table of the Accessory I/O pairs.

## Relay I/O

The Relay I/O use active low inputs. When the Relay Inputs are floating (nothing connected) the inputs are set at 5V and the corresponding Relay Outputs will have continuity between COM and N.C. When the Relay Input is set to 0Volts (ground) the input will activate the corresponding Relay Output. The Relay Outputs will have continuity between COM and N.O. when the relay is activated and will hold this state for as long as the Relay Input is set to 0Volts. The Relay Inputs can be tested by making a jumper connection to ground and monitoring the change in continuity of the Relay Outputs.

Relay 3 functions as a Supervision relay when DIP switch 4 is on in Run Mode; a Supervision relay monitors the condition of the communication link between the Central and Remote units. While in Supervision mode, Relay 3 is activated when the communication link between the Central and Remote is established and functioning. Relay 3 will deactivate (Alarm condition) when either the Relay 3 Input on the remote is active (pulled low) OR the Remote unit is unable to communicate with the Central unit. See APPLICATION NOTE FOR DETAILS.

## LED and AUX I/O

The LED and AUX I/O use active low inputs. When the inputs are floating (nothing connected) the associated output will be set to a high level (5V). When the input is set to 0Volts (ground) the input will activate its associated output. All Accessory outputs are Open Collector type and will switch to ground when activated and will hold this state as long as the input is set to 0Volts. Each input will have an associated output. Inputs can be tested by making a jumper connection to ground and monitoring the associated output.

### Accessory I/O Pairs

INPUT	OUTPUT
Relay 1 Input (C)	Relay 1 COM, Relay 1 N.C., Relay 1 N.O. (R)
Relay 2 Input (C)	Relay 2 COM, Relay 2 N.C., Relay 2 N.O. (R)
Relay 3 Input (R)	Relay 3 COM, Relay 3 N.C., Relay 3 N.O. (C)
Relay 4 Input (R)	Relay 4 COM, Relay 4 N.C., Relay 4 N.O. (C)
LED Input (C)	LED Output (R)
Aux Input (R)	Aux Output (C)

*(C) or (R) denotes whether the pin is located on the board of the Central unit (C) or Remote unit (R).*

# Cypress Suprex® TCP/IP Series - Accessory I/O - Central Relay Inputs

To activate the relay on the Remote unit, connect as shown below. These connections can be used to allow the Remote relay to operate a DOOR STRIKE, GATE, or other locking hardware. The diagram below shows two methods of triggering the relays. The first method uses a dry contact to trigger the relay. The second method shows the LED signal triggering the LEDs.

Relays 1 and 2 are available for accessory outputs at the Remote end. Either relay can be used to provide the Door Strike or Gate Activation function. This example uses Relay 1. The Relay Input pin is normally high (5V). When the Relay Input pin is pulled low (0V) the corresponding relay on the Remote unit will be activated. When the relay is activated, the Relay Output pins will change continuity from N.C. and COM to N.O. and COM (not shown in diagram).

## Relay Input Wiring Example - Door Strike Follows Dry Contact

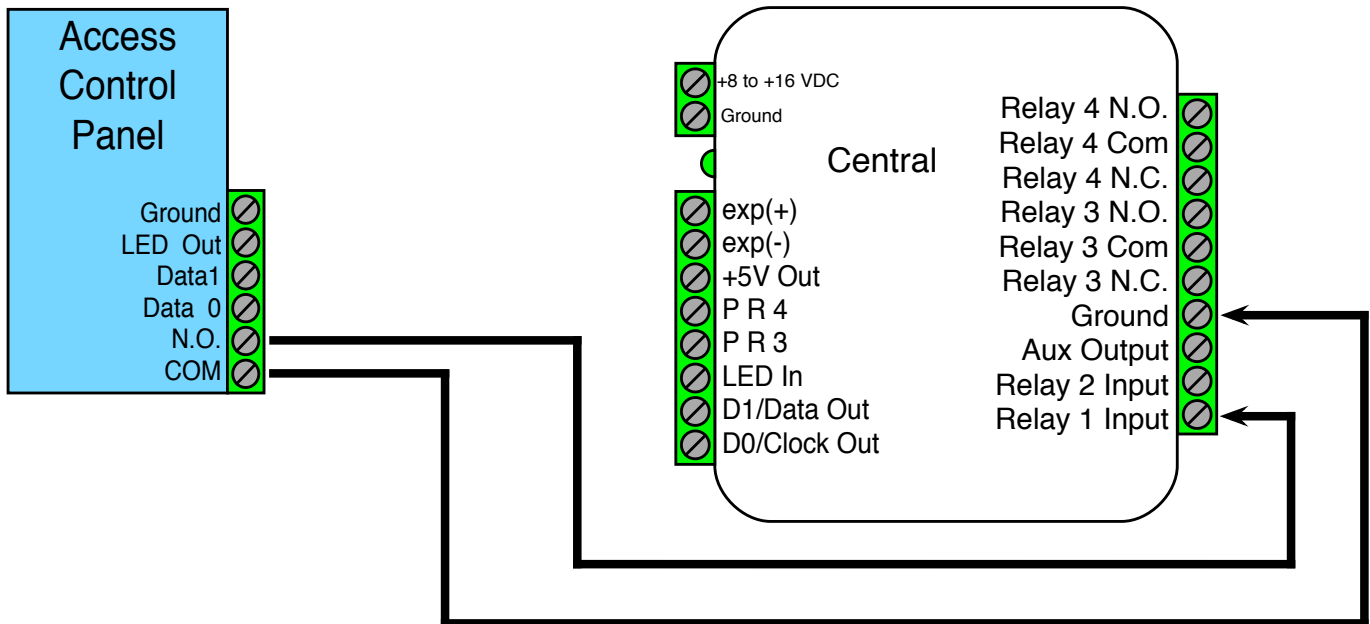

## Relay Wiring Example - Door Strike Follows LED

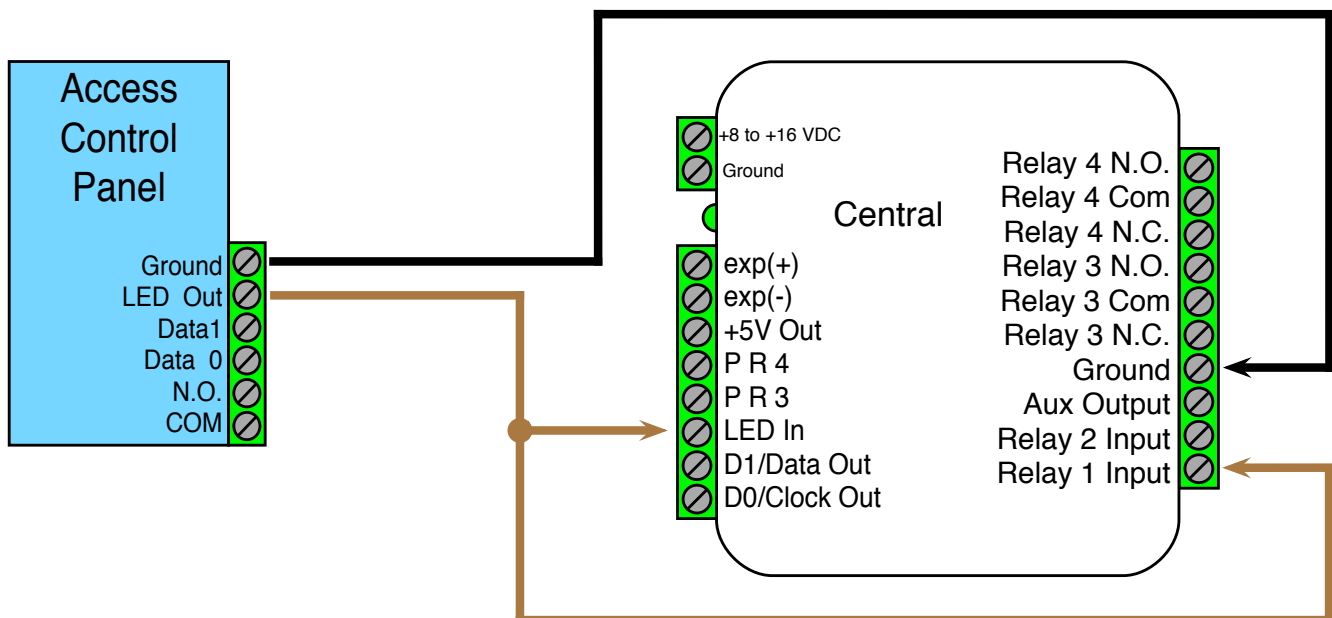

# Cypress Suprex® TCP/IP Series - Accessory I/O - Relay 1 & 2 I/O

## Relay 1 I/O Diagram

This diagram shows how the state of the the Relay 1 Outputs change as the Relay 1 Input is set to 0Volts (connected to ground) using a jumper connection. The left side shows that when Relay 1 Input is not set to 0Volts, Relay 1 COM and Relay 1 N.C. have continuity. The right side shows that when Relay 1 Input is set to 0Volts, Relay 1 COM and Relay 1 N.O. have continuity.

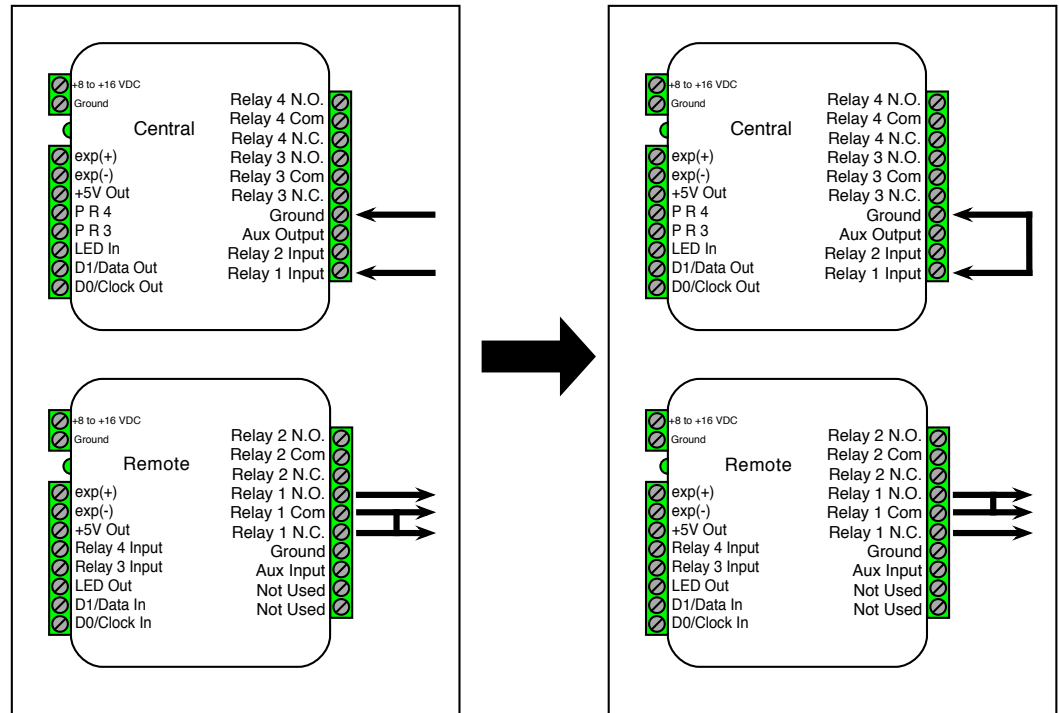

## Relay 2 I/O Diagram

This diagram shows how the state of the the Relay 2 Outputs change as the Relay 2 Input is set to 0Volts (connected to ground) using a jumper connection. The left side shows that when Relay 2 Input is not set to 0Volts, Relay 2 COM and Relay 2 N.C. have continuity. The right side shows that when Relay 2 Input is set to 0Volts, Relay 2 COM and Relay 2 N.O. have continuity.

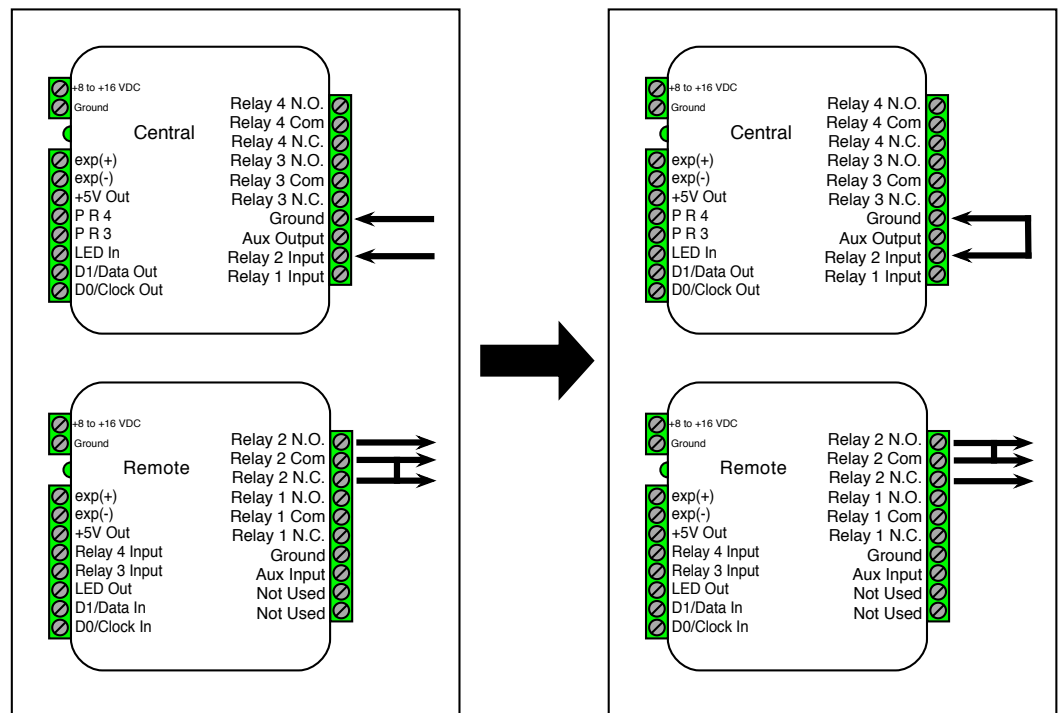

# Cypress Suprex® TCP/IP Series - Accessory I/O - Remote Relay Inputs

To activate the relay on the Central unit, connect as shown below. These connections can be used to operate a REX switch or other signals that need to go to the access panel.

Relays 3 and 4 are available for accessory outputs at the Central end. Either Relay 3 or Relay 4 can be used. This example uses Relay 4. The Relay Input pin is normally high (5V). When the Relay Input pin is pulled low (0V) the corresponding relay on the Remote unit will be activated. When the relay is activated, the relay output pins will change continuity from N.C. and COM to N.O. and COM (not shown in diagram).

Relay 3 can be used to send signals to the access panel while Supervision mode is active, but it is important to remember that the outputs will be reversed. When Supervision mode is active and the Relay 3 Input pin is normal (5V) the relay output pins will have continuity between N.O. and COM. When Supervision mode is active and the Relay 3 Input pin is active (0V) the relay output pins will have continuity between N.C. and COM.

## Relay Wiring Example - REX Switch

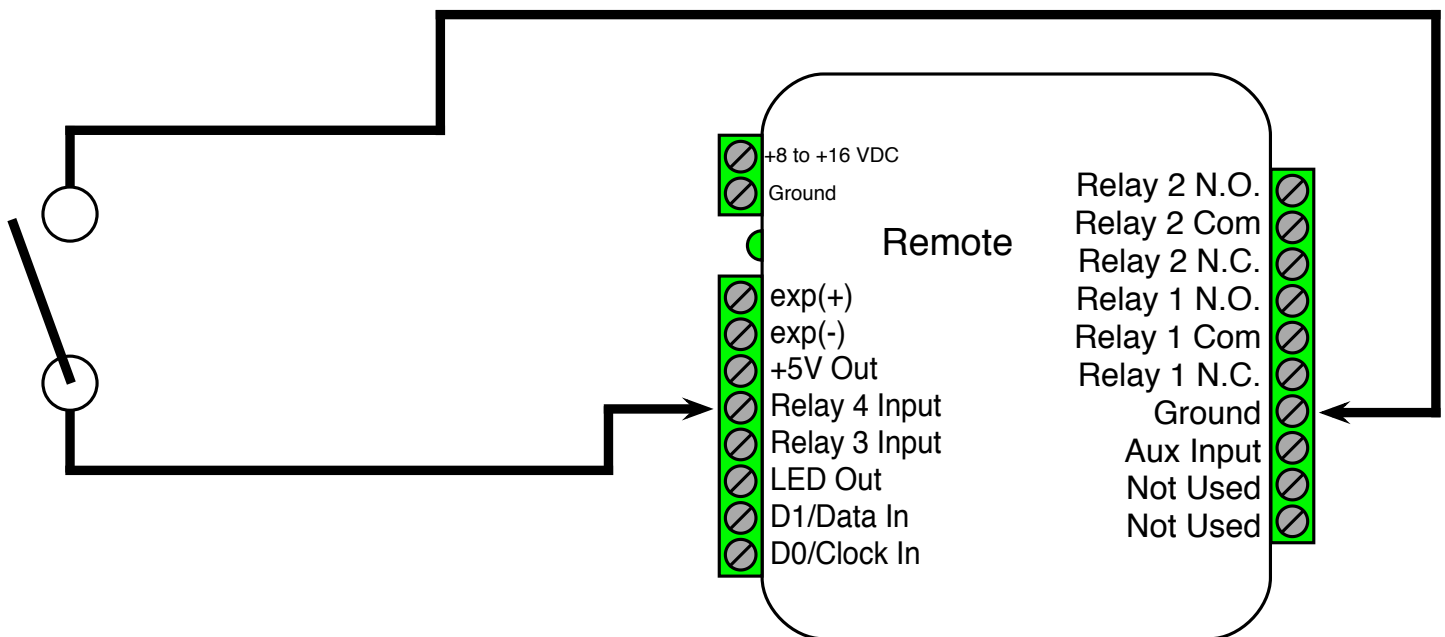

# Cypress Suprex® TCP/IP Series - Accessory I/O - Relay 3 & 4 I/O

## Relay 3 I/O Diagram

This diagram shows how the state of the the Relay 3 Outputs change as the Relay 3 Input is set to 0Volts (connected to ground) using a jumper connection. The left side shows that when Relay 3 Input is not set to 0Volts, Relay 3 COM and Relay 3 N.C. have continuity. The right side shows that when Relay 3 Input is set to 0Volts, Relay 3 COM and Relay 3 N.O. have continuity.

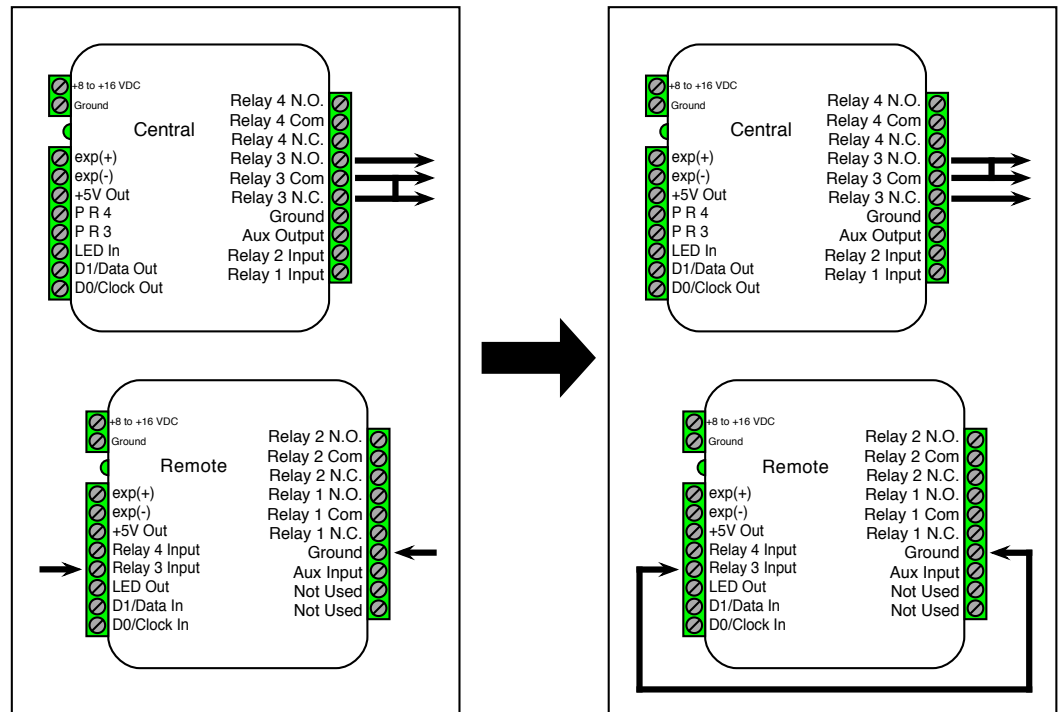

## Relay 4 I/O Diagram

This diagram shows how the state of the the Relay 4 Outputs change as the Relay 4 Input is set to 0Volts (connected to ground) using a jumper connection. The left side shows that when Relay 4 Input is not set to 0Volts, Relay 4 COM and Relay 1 N.C. have continuity. The right side shows that when Relay 4 Input is set to 0Volts, Relay 4 COM and Relay 4 N.O. have continuity.

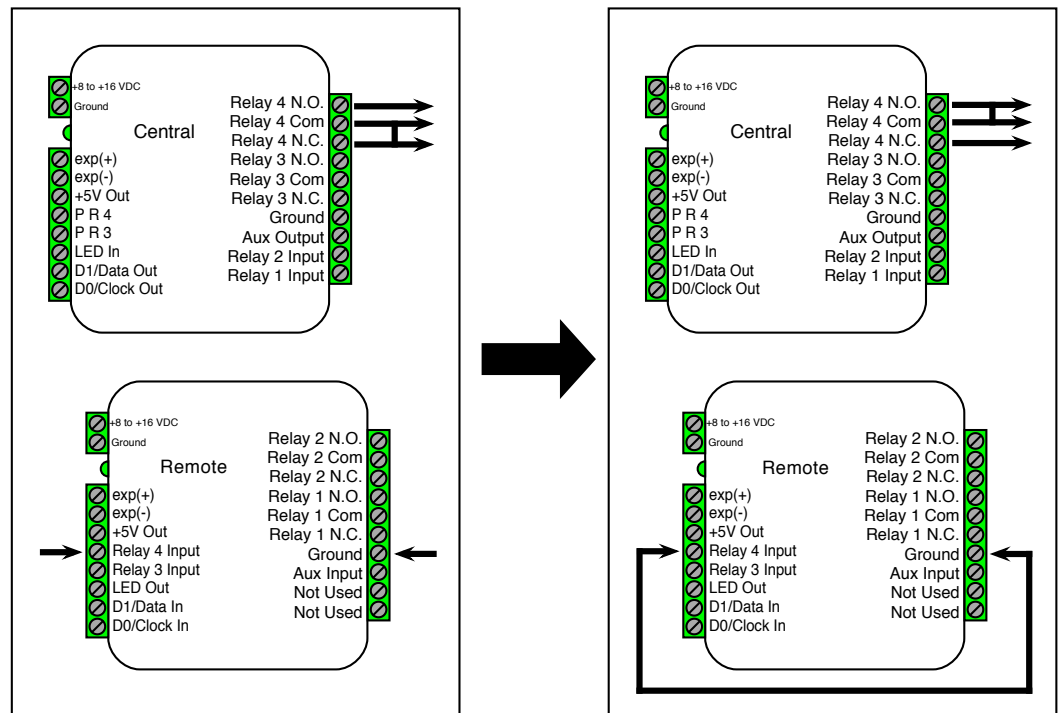

# Cypress Suprex® TCP/IP Series - Accessory I/O - LED I/O

For access control panels with a LED Output signal, the SPX-7200 is able to transmit this signal to the reader with the LED Input and LED Output pins. The LED In pin is a digital input and the LED Out pin is a digital output. The LED In pin has two states, 5V (high or normal) and 0V (low or active). The LED Out pin will mirror the state of the LED In pin.

The LED I/O Signal Diagram below shows how this signal is passed through the SPX-7200.

## LED I/O Signal Diagram

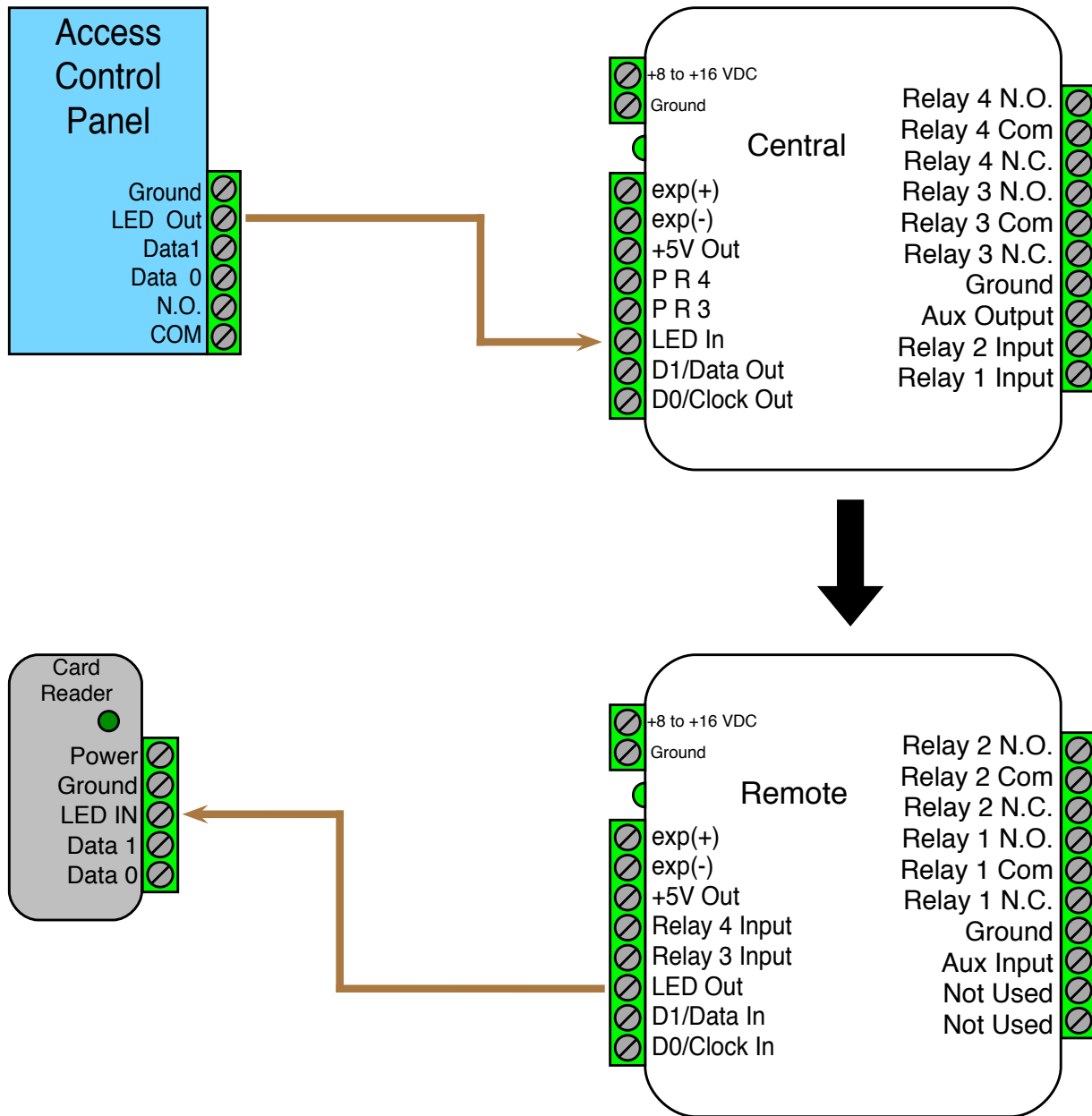

# Cypress Suprex® TCP/IP Series - Accessory I/O - AUX I/O

The SPX-7200 has an auxiliary I/O signal going from the reader side to the panel side. The SPX-7200 is able to transmit this signal to the panel with the AUX Input and AUX Output pins. The AUX In pin is a digital input and the AUX Out pin is a digital output. The AUX In pin has two states, 5V (high or normal) and 0V (low or active). The AUX Out pin will mirror the state of the AUX In pin.

The AUX I/O Signal Diagram below shows how this signal is passed through the SPX-7200.

## AUX I/O Signal Diagram

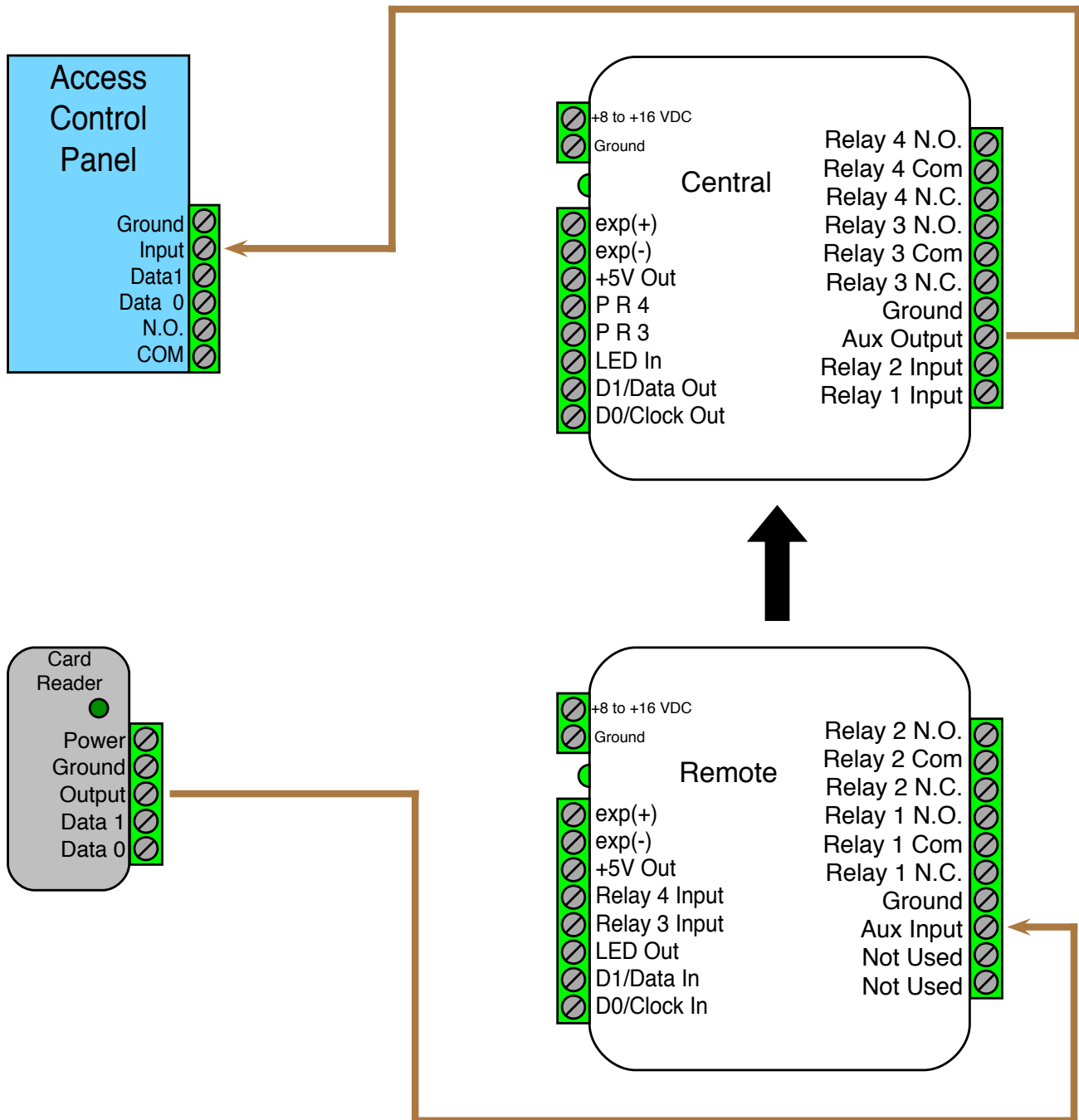

# Cypress Suprex® TCP/IP Series - Accessory I/O - Remote Digital Relay Inputs

Note: This section applies only to the Remote unit, which can use analog or digital relay inputs, since the Central unit has only digital relay inputs.

DIP switch 2 controls whether the Remote unit uses analog or digital relay inputs. By default, DIP switch 2 is off and the Remote unit is set to use analog relay inputs. Set DIP switch 2 to the ON position to use digital relay inputs on the Remote unit. The Remote unit's digital and analog relay inputs function in the same way; the digital relay inputs simply need to be connected to ground for the corresponding relay to be activated.

To activate the digital relay inputs, only DIP switch 2 on the Central board needs to be enabled. DIP switch 2 on the Remote board has no function. It may be necessary to power-cycle the Central unit for the change to take effect.

Note: The digital relay input pins are not the same Relay 3 and Relay 4 input pins labeled on the Remote unit. Instead, the digital relay input pins use the two "Not Used" pins on the 10 pin header. The "Not Used" pin on the outside of the board is the new Relay 3 input pin, the other "Not Used" pin is the new Relay 4 input pin. Use the diagram below as a reference.

For most applications the analog relay inputs are sufficient. But for instances where a significant delay is noticed in the activation of Relay 3 and Relay 4, the end user should switch to using digital relay inputs. The digital relay input pins are able to detect a signal change faster than the analog inputs are, and this may eliminate the delay in the activation of the relay.

**Note regarding EXP units:** While DIP switch 2 is on and the digital relay input pins are enabled on the SPX-7200 units, the digital relay inputs are also enabled on any EXP-2000 Remote units that are connected. The digital relay input pins are on the 12 pin header and are the two "Not Used" pins. The outside "Not Used" pin is the Relay 3 Input pin and the other "Not Used" pin is the Relay 4 Input pin.

## Analog and Digital Relay Input Pins

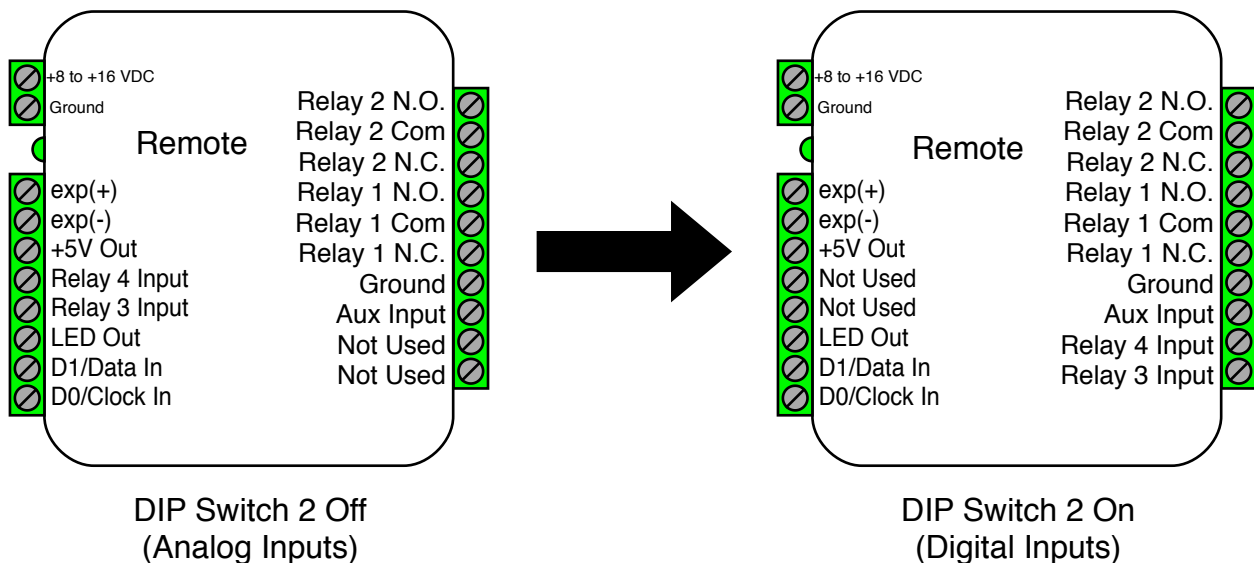

# Application Note on using Supervised contacts with the Suprex® TCP/IP Series

The following applies to these products: SPX-7200.

This application note describes the connections necessary to convey supervised contact status over a Suprex. The configurations described in this application note should apply to most panels which utilize supervised contacts. When connected as described, the Suprex provides a supervised signal to the panel interface by reading the supervised status of the contacts connected to the Suprex Remote unit.

**Theory of operation:** The access control panel is looking for a certain value of resistance connected to the supervised contact terminals. The Suprex Central unit will provide these resistance values locally at the panel so that the correct supervised status is maintained. At the same time, the Remote unit must maintain supervision of the wires connected to the relays and switches connected to the remote access point. The contact supervision is provided by the Remote unit. The Suprex system does this by comparing the value of programming resistor at the Central unit with the resistance seen at the Remote interface terminals. When there is a difference in the two values, the Relay on the Central unit is activated.

There are two different examples. One example is monitoring a normally closed contact at the Remote unit, and the other example is monitoring a normally open contact at the Remote unit. In the examples given, a normally closed contact will require a programming resistor of 1K and a normally open contact will require a programming resistor of 2K. Other resistor values can be used, but 1K resistors are the most common. Other resistance values will require different value(s) for the programming resistor(s).

## Normally Closed Contact

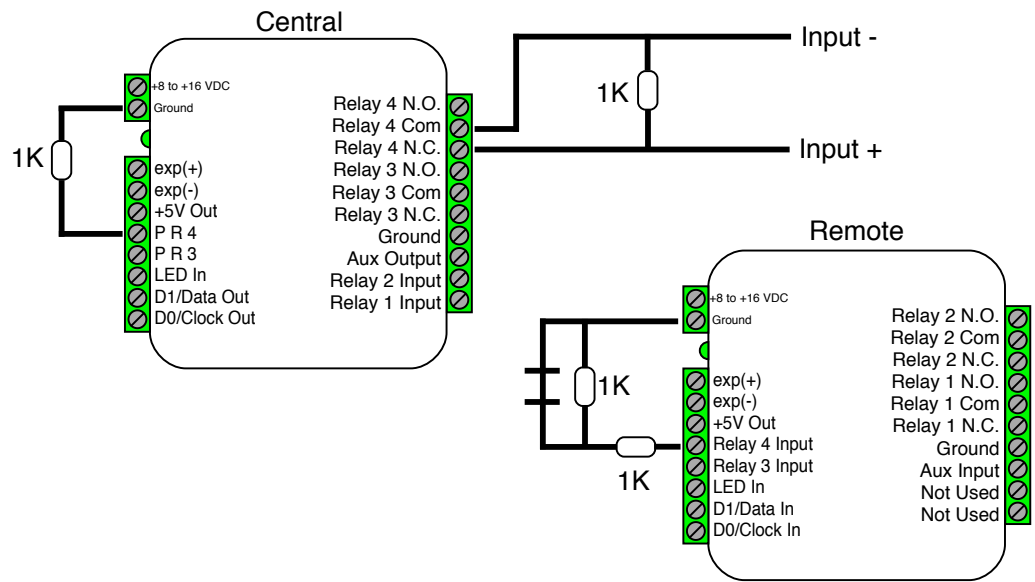

## Normally Open Contact

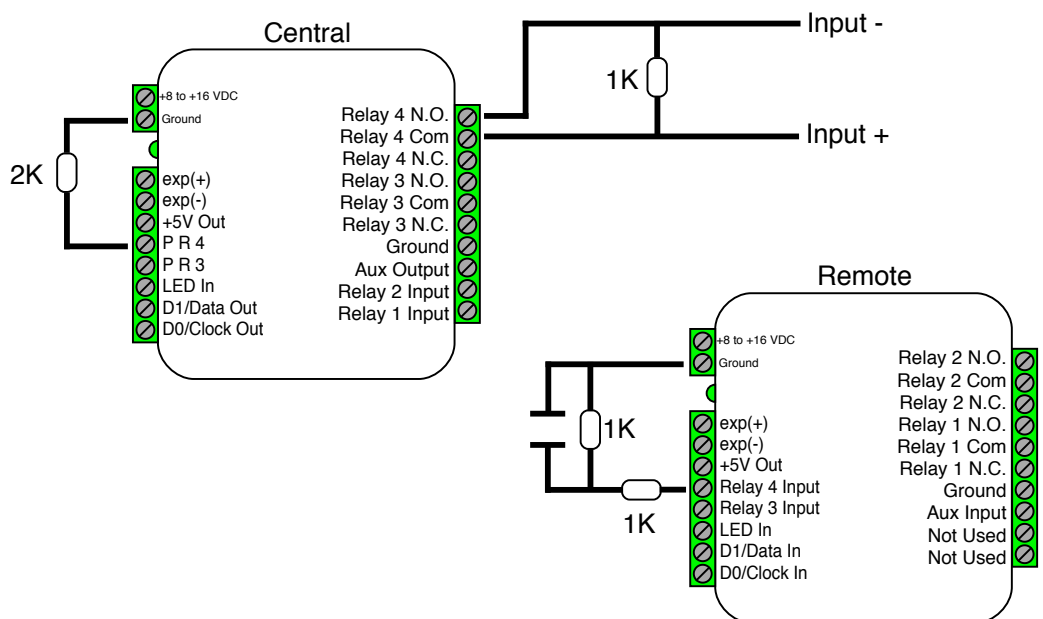

# Cypress Suprex® Addendum - Using EXP-2000 Expansion Pairs

EXP-2000 Expansion Pairs allow additional readers to connect to the access control panel using a single Suprex Ethernet link. This is useful at door/gate locations with more than one card reader, such as in/out door readers or high/low gate readers. The Suprex Ethernet can accommodate a maximum of 8 readers with the use of 7 EXP-2000 Expansion Pairs. Each reader requires its own data port on the access control panel.

Before using EXP-2000 Expansion Pairs with the Suprex system, it will be necessary to perform a short configuration process. This process determines how many Expansion Pairs will be used with the Suprex system. Each Suprex link can support up to 7 Expansion Pairs.

## Operation Overview:

The EXP-2000 pair of units is connected to the Suprex pair of units via an RS-485 connection. The EXP Central units will be daisy-chained off the Suprex Central RS-485 port (labeled **EXP+** and **EXP-**). The EXP Remote units will be daisy-chained off the Suprex Remote unit RS-485 port (also labeled **EXP+** and **EXP-**). The only link between the reader/gate location and the panel will be the Suprex link; in this case, the network link.

The Suprex and EXP-2000 Expansion Pairs operate on an addressing scheme. The Suprex pair is always Address 0. The first EXP pair will be Address 1, the second EXP pair will be Address 2, etc. (see pgs. 7-9). When configuring the Suprex pair to work with the EXPs, the Central and Remote units must be told how many EXP pairs they will be working with. The Central and Remote units of each EXP pair must be configured with their address numbers.

**Setup Process:** By default, Suprex units are not configured to accommodate EXP-2000 Expansion Pairs. To reconfigure the Suprex units, follow this process for both the Central and Remote units.

- The Suprex Central and Remote units must be configured with the total number of EXP pairs being used.
  - This is configured in the Run Mode settings and is controlled by DIP switches 6, 7, and 8.
  - Change settings on both the Suprex Central and Remote units. (See pgs. 7 - 9)
- The EXP-2000 Expansion Pair pairs need to be properly addressed with their address number.
  - The EXP address is configured by using DIP switches 6, 7, and 8 on the EXP-2000 Central and Remote units.
  - The first EXP pair will be Address 1, the second EXP pair will be Address 2, etc. (See pgs. 7 - 9).
  - Set DIP switch 8 on the EXP Central and Remote units to set to Address 1.
  - Set DIP switch 7 on the EXP Central and Remote units to set to Address 2.
- Connect the EXP Expansion Pairs into the system as indicated in the wiring diagrams. (See pgs. 35 - 36)

**Suprex Operation with Expansion Pairs:** Using EXP Expansion Pairs does not change the normal function of the Suprex, with these exceptions:

- EXP Expansion Pairs are compatible only with the Wiegand interface type (does not apply to Wiegand No Filter)
- If the Suprex Supervision relay is enabled, the Supervision relay will deactivate (indicate alarm state) if the communication link fails between the Suprex pair or ANY of the the EXP pairs. If the Supervision Relay is going to be used, it will need to be enabled. (See pgs. 7 - 9)
- LED Indicators with Suprex Pair:
  - Suprex Central or Remote status LED is solid green in Run Mode: one or more of the connected EXP units is not communicating properly. Ensure all EXP units are powered and correctly wired.
  - EXP status LED is solid red: EXP unit is not properly communicating with the Suprex unit. Ensure the Suprex unit is powered and wired correctly.
  - EXP status LED is flashing green: EXP unit is properly communicating with the Suprex.
- The EXP-2000 Central and Remote pair will be functionally similar to the standard Cypress SPX-1300 Suprex system. For more details, see the EXP-2000 manual.

# Cypress Suprex® Addendum - Suprex Central and EXP Central Wiring Diagram

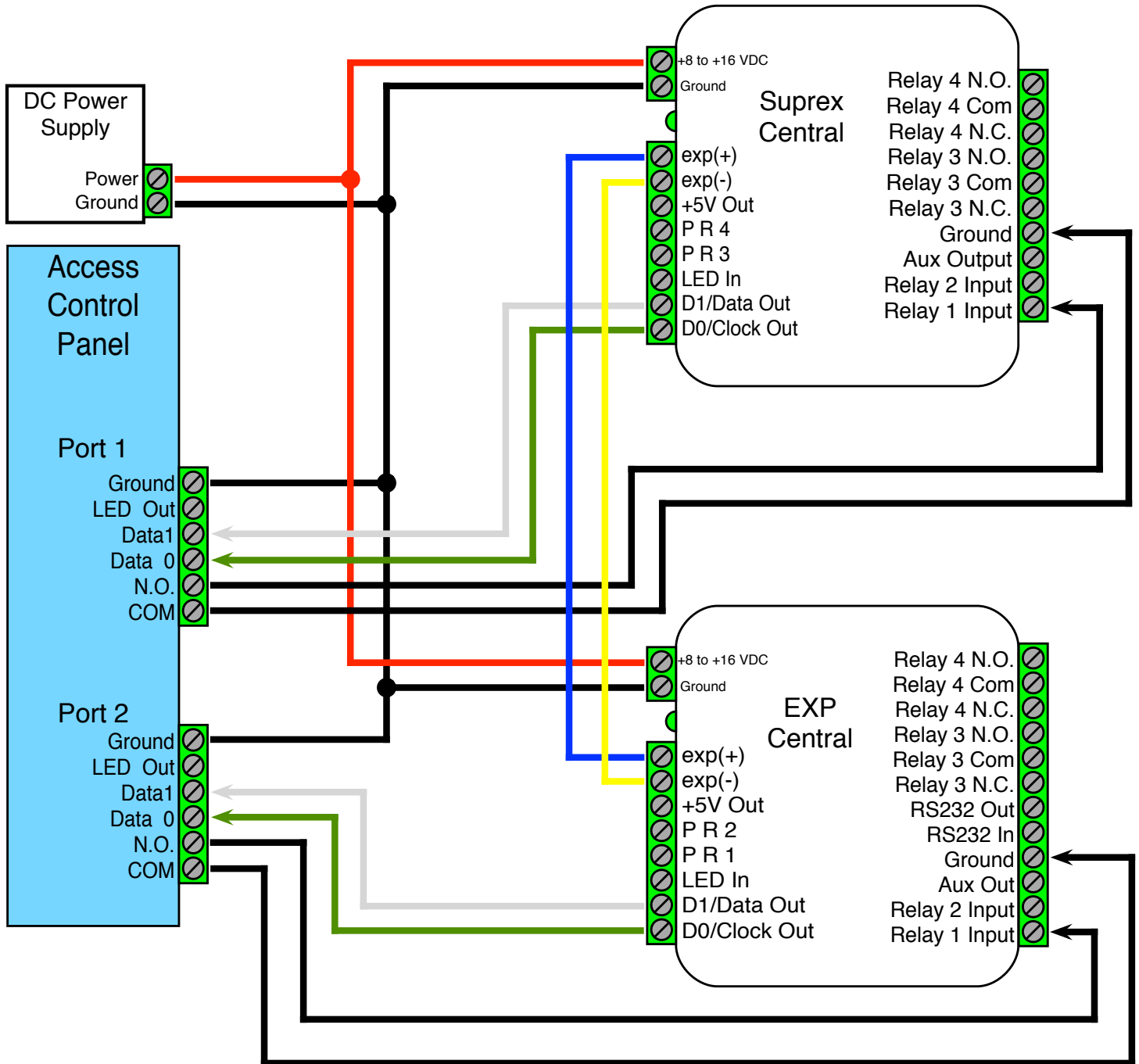

# Cypress Suprex® Addendum - Suprex Remote and EXP Remote Wiring Diagram

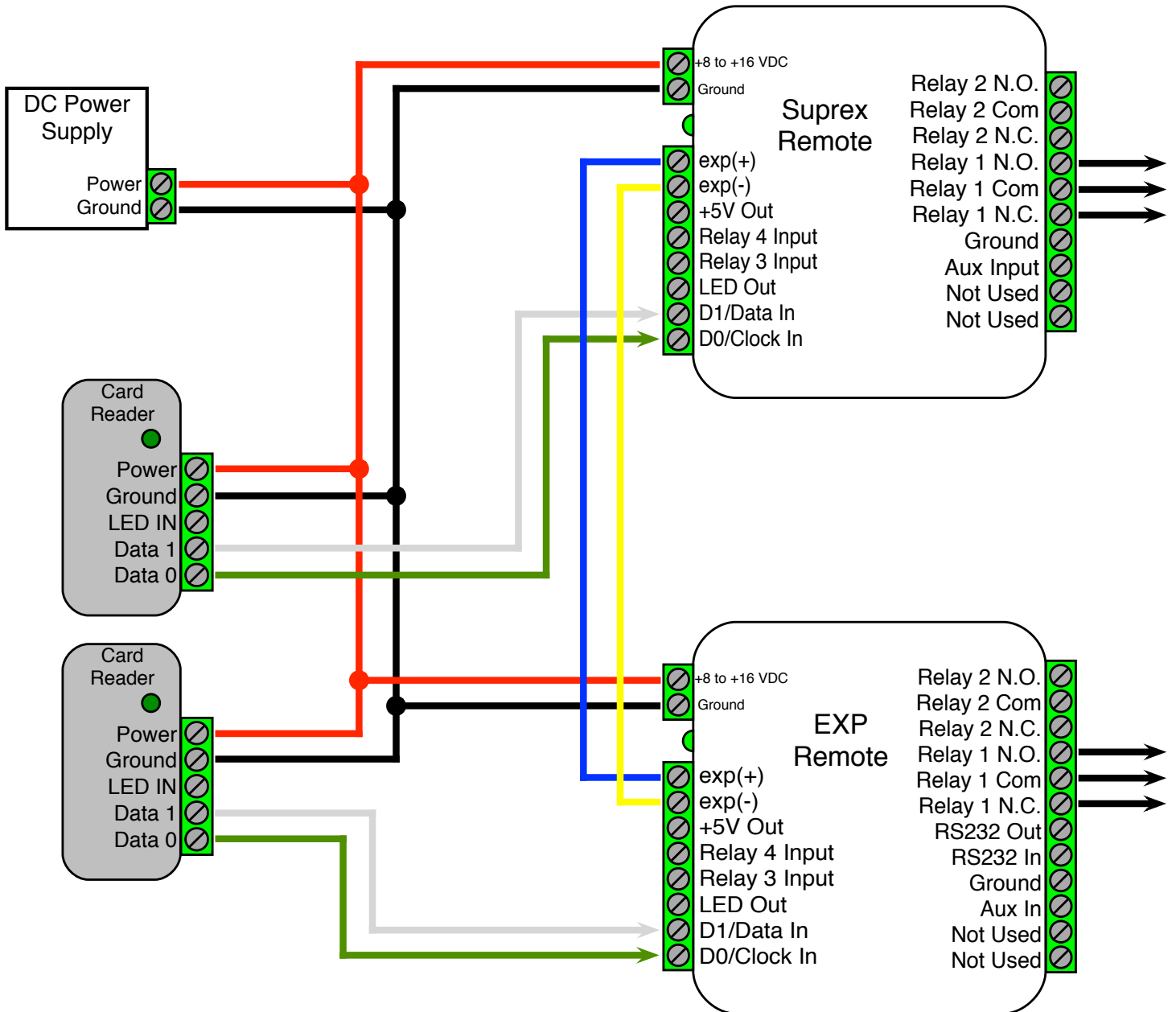

See EXP-2000 Manual for further setup instructions.