

Product Overview

The ODM-2000 product family acts as an OSDP Data Splitter (or multiplexer). An OSDP Splitter serves to connect an OSDP reader with either:

- Two OSDP access control units (ODM-2010 & ODM-2020)
- An OSDP access control unit and a Wiegand control panel (ODM-2015 & ODM-2030)

Additionally, the ODM-2000 product family offers both standard and custom OSDP splitters.

Applications

- Multi-tenant buildings
- Connect an OSDP reader to an ACU and secondary system, such as a key cabinet or time & attendance system
- Connect one OSDP reader to two access control systems.

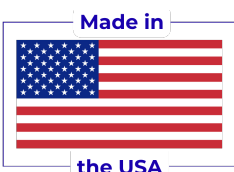

Firmware Versions
ODM-2010 v1.0.2
ODM-2015 v1.0.2
ODM-2020 (custom)
ODM-2030 (custom)

ODM-2000_Manual_260528

Cypress ODM-2000 Series OSDP Splitter Manual - Features and Specification

- ODM-2010 & ODM-2020: connect an OSDP reader to two OSDP ACUs.
- ODM-2015 & ODM-2030: connect an OSDP reader to two systems: an OSDP ACU and a Wiegand controller.

Specifications				
	Part Number	Description	Systems Supported	UPC
Part Number	ODM-2010	Standard	OSDP	816684005022
	ODM-2015	Standard	OSDP / Wiegand	816684005329
	ODM-2020	Intelligent / Custom	OSDP	Custom - N/A
	ODM-2030	Intelligent / Custom	OSDP / Wiegand	Custom - N/A
Physical	Physical Dimensions (L x W x H)		4.50 x 2.85 x 0.94 inches	114.30 x 7.24 x 2.39 cm
	OSDP Ports		3 OSDP Ports 1 ACU Port (Reader) and 2 PD Ports (Access Controller)	
Environmental	Operating Temperature Range		-40°F to 158°F	-40°C to 70°C
	Enclosure Rating		Not rated for water or dust intrusion.	
Electrical	Supply Voltage		8 - 16 Vdc @ 300 mA	
	Relays	Max Switching	220Vdc 30W (resistive) 1A / 250Vac 37.5VA 1A	
		Running Spec with load	30Vdc 1A (resistive) / 125 Vac 0.3A (resistive), 1x10 ⁵ operations @ 20°C	
LED Indicators	ACU Port LED (P0)		Indicates status of ACU Port (No Communication, Clear Channel Session, Secure)	
	PD Port LEDs (P1 & P2)		Indicates status of PD Ports (No Communication, Clear Channel Session, Secure)	
	Status LED		Indicates status of the ODM-2000 (Powered Off, Running)	

Cypress ODM-2000 OSDP Splitter Series Manual - Table of Contents

Table of Contents	
Topic	Page
Overview and Specifications	1-2
Approximate Dimensions & Product Comparison	4
LED Indication	5
Wiring Diagrams	6-7
General OSDP Information / Capabilities	8
Supported OSDP Messages	9
OSDP Transparency & Splitting	10
Standard Credential Routing	11
Custom Credential Routing	12
OSDP Initialization Sequence	13
Troubleshooting	14
OSDP Terminology	15-16

Cypress ODM-2000 Series OSDP Splitter Manual - Approximate Dimensions

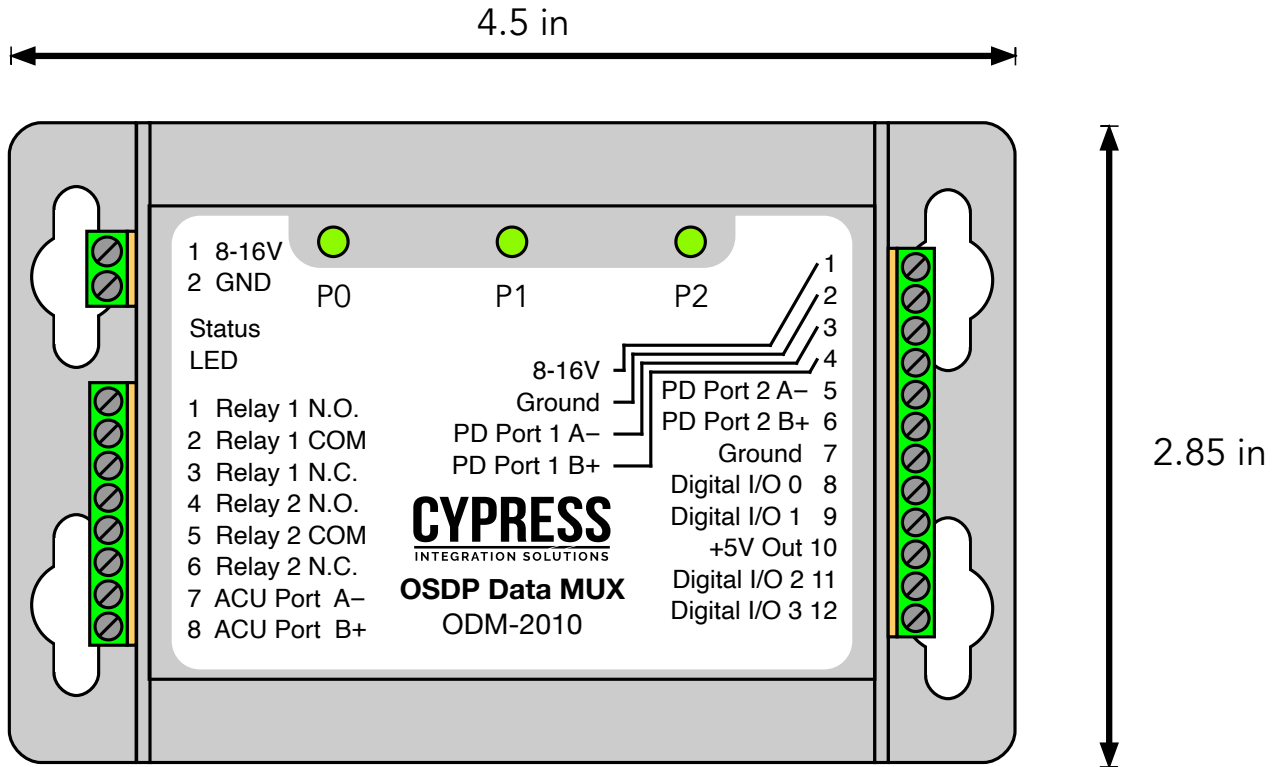

Cypress ODM-2000 Series OSDP Splitter Manual - Product Comparison

	OSDP Panels	OSDP & Wiegand Panel	Type
ODM-2010	√		Standard
ODM-2015		√	Custom
ODM-2020	√		Standard
ODM-2030		√	Custom

Cypress ODM-2000 Series OSDP Splitter Manual - LED Indication

The ODM-2000 product family has a bi-color status LED located between the 2-pin and 8-pin connector. This LED indicates the operational status of the ODM-2000.

Status LED State	Description
Off	No power
Red	Error; invalid state
Flashing Green	Normal operation

Additionally, the ODM-2000 product family has three bi-color LEDs on the top face of the unit. Each OSDP Port LED indicates the status of each OSDP connection.

LED Name	Description
P0	Communication status between the ACU Port and the OSDP reader.
P1	Communication status between the PD Port 1 and the Primary OSDP ACU.
P2	Communication status between PD Port 2 and the: <ul style="list-style-type: none"> • Secondary OSDP ACU (ODM-2010 & ODM-2020) • Wiegand Panel (ODM-2015 & ODM-2030)

Port LED State	Description	
Solid Red	No communication on this port	
Flashing Red	<i>P0</i>	<i>P1 & P2</i>
	Searching for reader	OSDP communication present, but not communicating with the ODM-2000
Flashing Green	Clear channel OSDP communication	
Solid Green	Secure channel OSDP communication	
Flashing Red & Green	Special OSDP reply transmitted: <ul style="list-style-type: none"> - osdp_RAW, osdp_KEYPAD - osdp_ISTATR, osdp_OSTATR, osdp_LSTATR, osdp_RSTATR 	

Cypress ODM-2000 Series OSDP Splitter Manual - Wiring Diagrams

Diagram 1: ODM-2010 & ODM-2020 Wiring

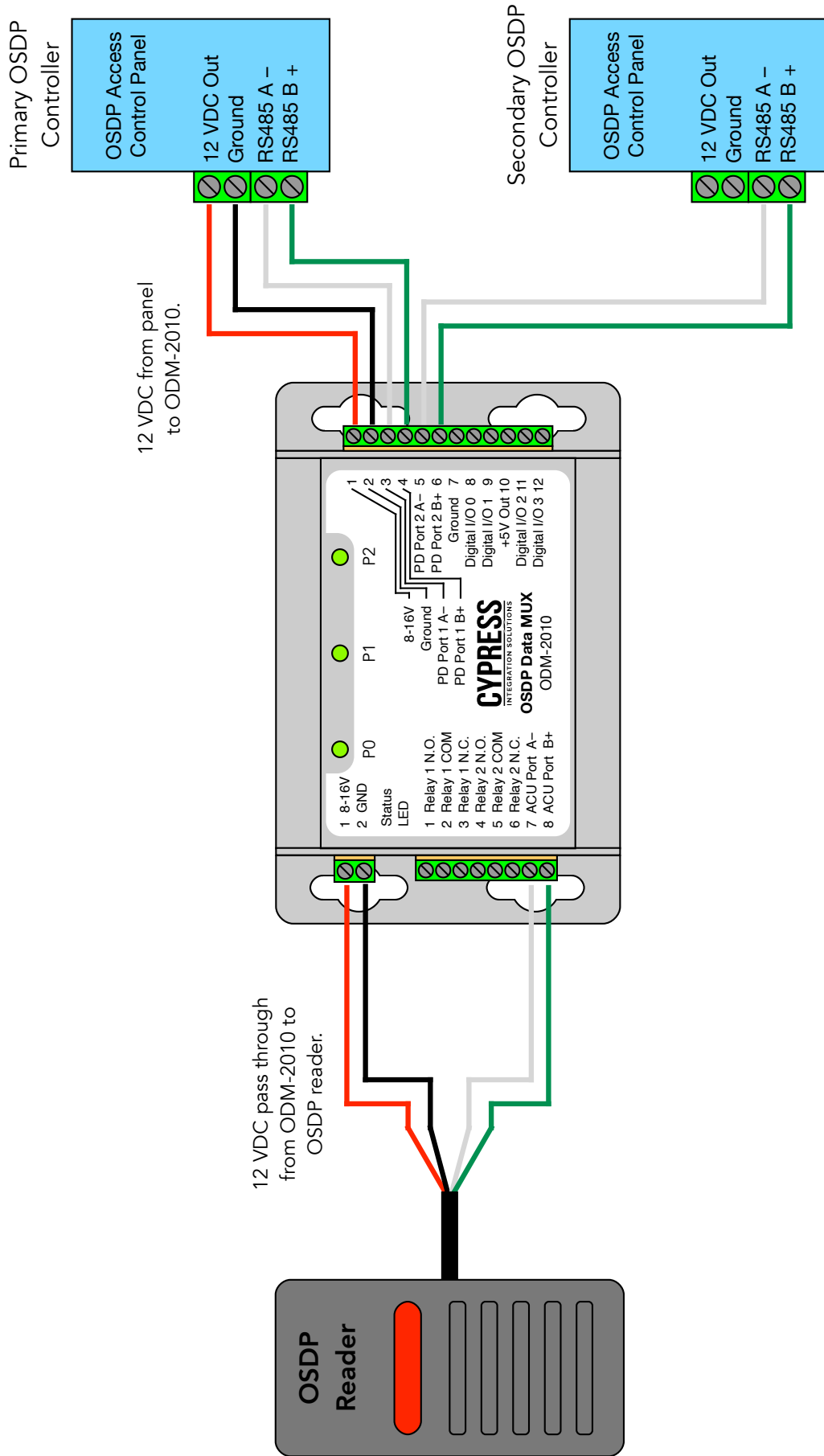
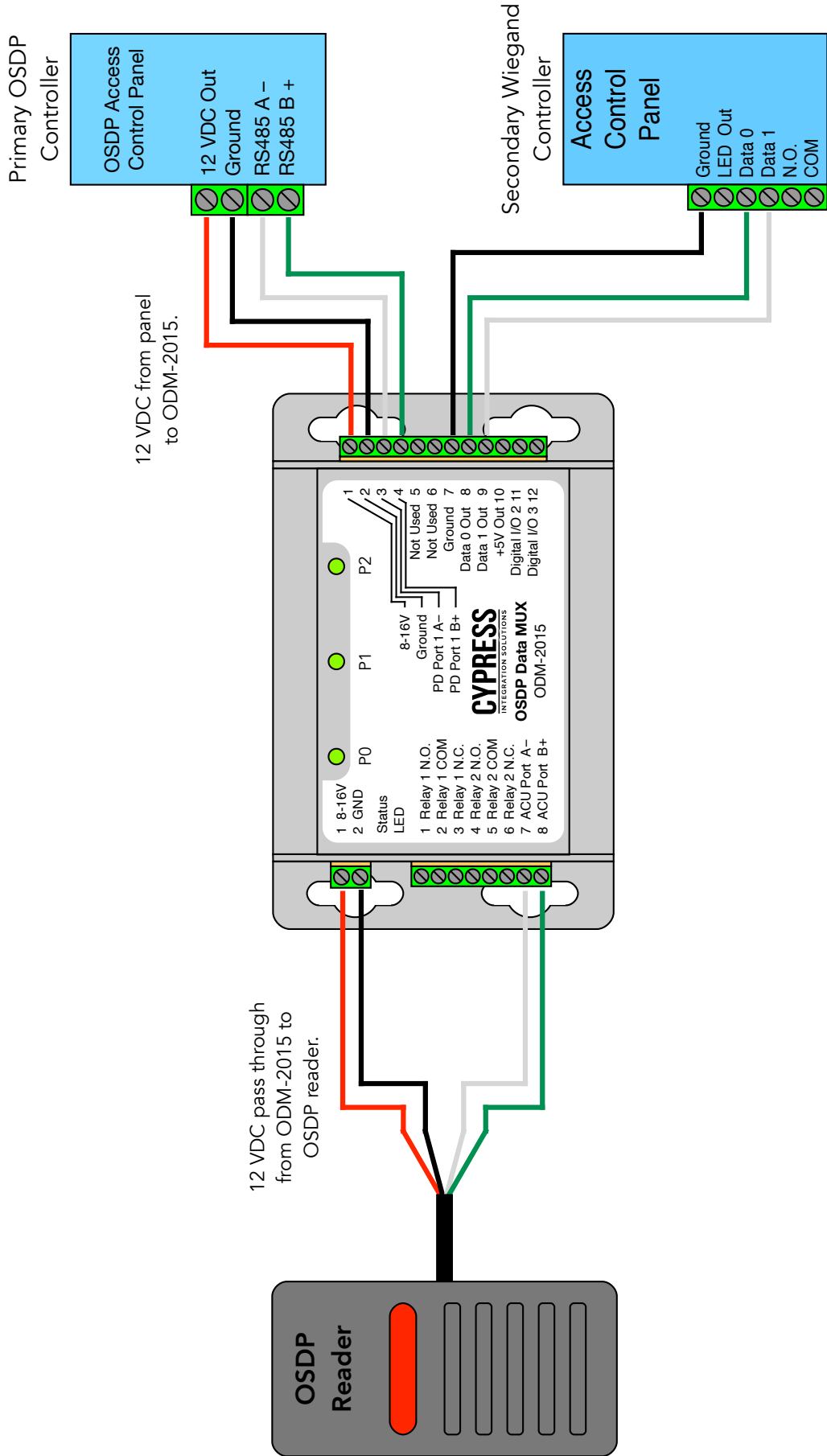

Diagram 2: ODM-2015 & ODM-2030 Wiring



Cypress ODM-2000 Series OSDP Splitter Manual - General ODSP Information /

The Cypress ODM-2000 Series OSDP Splitter Manual product family acts as both an OSDP ACU and PD. The ACU port connects to an OSDP reader (PD); on this port, the ODM-2000 acts as an ACU, controlling the attached reader. The PD Port 1 connects to an OSDP ACU; on this port, the ODM-2000 acts as a PD, obeying the primary ACU. Likewise, ODM-2010 and ODM-2020 devices act as a PD on PD Port 2, listening to the secondary ACU. Below are capabilities shared on the ACU and PD ports.

Supported Communication Baud Rates (supported by all three OSDP ports)

9600, 19200, 38400, 57600, 115200, & 230400

Supported Device Addresses

ACU Port

Device addresses 0-126 (0x00 - 0x7F) are supported. The Broadcast Address 127 (0x7F) is supported and used to discover the OSDP reader's devices address.

PD Port 1

Device addresses 0-124 (0x00 - 0x7C) are supported. The Broadcast Address 127 (0x7F) is supported and allows the connected ACU to discover the ODM-2000.

Address 125 (0x7D) is a special configuration address used to directly communicate with an ODM-2000. Any `osdp_PDID` and `osdp_PDCAP` reports reflect the ODM-2000 itself, not the reader connected to the ACU Port. Additionally, when communicating with address 125, `osdp_FILETRANSFER` can be used to upload new firmware images to the ODM-2010. This special address is intended to be used to check the serial number and firmware of the ODM-2000, and for firmware upload. Unless there are coms on the ACU port, PD Ports 1 and 2 cannot be configured. The `osdp_FILETRANSFER` feature can only be used to update the ODM-2000 firmware, not the firmware of the connected OSDP reader/PD.

This special address cannot be polled along with the simulated reader's address!

PD Port 2

Device addresses 0-126 (0x00 - 0x7F) are supported. The Broadcast Address 127 (0x7F) is supported and allows the connected ACU to discover the ODM-2000.

Default Communication Settings

PD Port 1 & PD Port 2: address 0 at 9600 baud

ACU Port: defaults to PD Port 1 configuration; automatically discovers reader

Secure Channel

Supported on all OSDP ports.

Note: The SCBK on the ACU port and PD Port 1 always match.

Cypress ODM-2000 Series OSDP Splitter Manual - Supported OSDP Messages

Table 4 below shows OSDP messages that are supported on all OSDP ports. Any messages not listed below will be ignored by the ODM-2000. All commands are sent from an ACU to a PD. Likewise, all replies are sent from a PD to an ACU.

Commands	Replies
osdp_POLL	osdp_RAW
osdp_ID	osdp_KEYPAD
osdp_COMSET	osdp_NAK
osdp_CHLNG	osdp_CCRYPT
osdp_SCRYPT	osdp_RMAC_I
osdp_KEYSET	osdp_ACK
osdp_BUZZ	osdp_ISTATR
osdp_LED	osdp_OSTATR
osdp_OUT	osdp_RSTATR
	osdp_LSTATR
	osdp_PDID
	osdp_PDCAP

Table 4: Supported OSDP commands and replies

Cypress ODM-2000 Series OSDP Splitter Manual - OSDP Transparency & Splitting

ACU Port

Certain replies sent from the attached OSDP reader (PD) to the ACU Port will be passed through to the appropriate simulated PD port(s). In this scenario, the ODM-2000 acts as transparent connection between the reader and the ACU(s). Table 5 below shows which OSDP replies are transparent, and which PD port(s) they will be re-transmitted through.

Reply	PD Port 1 (Primary ACU)	PD Port 2 (Secondary ACU)
osdp_RAW	√	√
osdp_KEYPAD	√	√
osdp_ISTATR	√	
osdp_OSTATR	√	
osdp_RSTATR	√	
osdp_LSTATR	√	
osdp_PDID	√	√
osdp_PDCAP	√	√

Table 5: Transparent OSDP replies

PD Port 1

This is the Primary PD port. Certain commands sent from the OSDP ACU will be passed through to the OSDP reader (PD). For example, a multi-tenant building commonly requires one reader to be connected to two panels. In this scenario, the ODM-2000 acts as a transparent connection between the primary ACU and the reader. The following OSDP commands are transparent on the primary port and will be re-transmitted to the reader:

- osdp_OUT
- osdp_LED
- osdp_BUZ
- osdp_KEYSET

PD Port 2

This is the Secondary PD port. There are no transparent commands on the secondary port. No commands send from this ACU will be re-transmitted to the OSDP reader (PD). In the multi-tenant building example, the ODM-2000 connects the secondary ACU and the reader; however, the ODM-2000 will not re-transmit OSDP I/O commands to the reader.

Cypress ODM-2000 Series OSDP Splitter Manual - Standard Credential Routing

The ODM-2010 and ODM-2015 are standard OSDP splitters. They come programmed with a generic credential routing scheme.

ODM-2010

The ODM-2010 directs all credentials to both connected the primary and secondary ACUs.

ODM-2015

The ODM-2015 directs all credentials to both the OSPD ACU and Wiegand controller.

Cypress ODM-2000 Series OSDP Splitter Manual - Custom Credential Routing

The ODM-2020 and ODM-2030 are custom products engineered specifically to suit the specific application. They can be programmed to direct credentials to the appropriate PD or Wiegand panel based on credentials' bit length and facility code. Multiple credential formats can be specified. "Everything Else" includes all credentials that do not match the specific configuration. Additionally, these custom configurations can utilize 2 relays and 4 I/O pins (ODM-2020) or 2 I/O pins (ODM-2030). For more information, please [contact Cypress](#).

ODM-2020

In the scenario a user needs to direct credentials to only one of connected ACUs, the ODM-2020 is a customized version of the ODM-2010. Below is an example demonstrating how smart credential routing works on the ODM-2020.

ODM-2020 Configuration

PD Port 1: 26 Bit Wiegand, FC = 33

PD Port 2: Everything Else

4327844 (dec) = 04209A4 (hex)

FC = 33 ID = 1234

As this credential has a matching bit length and facility code, it would be output on PD Port 1.

37104296 (dec) = 2362AA8 (hex)

FC = 27 ID = 5460

This credential does not have a matching bit length nor facility code, so it would be output on PD Port 2.

ODM-2030

In the scenario a user needs to direct credentials to only the OSDP ACU or Wiegand controller, the ODM-2030 is a customized version of the ODM-2015. Below is an example demonstrating how smart credential routing works on the ODM-2030.

ODM-2030 Configuration

PD Port 1: 35 Bit Wiegand, FC = 2330

PD Port 2: 35 Bit Wiegand, FC = 66

4886438721 (dec) = 123412341 (hex)

FC = 2330 ID = 37280

This credential would be output on PD Port 1.

139883273 (dec) = 8567309 (hex)

FC = 66 ID = 735620

This credential would be output on the Secondary Wiegand Port.

Cypress ODM-2000 Series OSDP Splitter Manual - OSDP Initialization Sequence

When establishing communication with an OSDP reader, the ODM-2000 performs the sequence outlined in the steps below.

1. The ODM-2000 sends the `osdp_POLL` command to the configured address at the configured baud rate.
2. Step 1 will be attempted 8 times. If a device is found, proceed to step 7.
3. If no device is found, the ODM-2000 will send the `osdp_ID` command on device address 127 (0x7F, broadcast).
4. If no device is found, the ODM-2000 will send the `osdp_ID` command on on device address 127 (0x7F, broadcast), cycling through all supported baud rates (9600, 19200, 57600, 115200, and 230400).
5. Step 4 is repeated until a device is found.
6. When a device is found, the `osdp_COMSET` command will set the device to the configured address at the configured baud rate.
7. If Secure Channel communication is not enabled, skip to step 10.
8. If Secure Channel communication is enabled, the ODM-2000 will attempt to establish a SCS. The `osdp_CHLNG` and `osdp_SCRIPT` commands are sent to the device, using the `SCBK_D` value specified by an `osdp_KEYSET` from the primary ACU on PD Port 1.
9. If a new key (SCBK) is required, the ODM-2000 sends the `osdp_KEYSET` command to the device. This sets the device's SCBK to the value specified by the primary ACU on PD Port 1.
10. An unencrypted or SCS has been established between the ODM-2000 and the OSDP reader. The ODM-2000 sends the `osdp_POLL` command to the reader until credential data is received in the form of the `osdp_RAW` or `osdp_KEYPAD` replies.

Note: The ODM-2000 will not enter Secure Channel with a PD until the primary ACU has initiated SC with the ODM-2000 on PD Port 1.

Cypress ODM-2000 Series OSDP Splitter Manual - Troubleshooting

If the ODM-2000 is not outputting data as anticipated, please follow the steps below:

1. **Communication:** Verify the ODM-2000 has communication on each port by examining the LEDs.
2. **Power:** If powering a Wiegand panel separately from the ODM-2000, ensure there is a common ground between the Wiegand panel and the ODM-2000. A common ground is not required for an OSDP reader.
3. **Inverted Data Lines:** Flip/reverse the reader data lines.
 - A. **Wiegand reader:** Look for garbage data.
 - B. **OSDP reader:** Will not communicate with the ODM-2000.
4. **OSDP:** Verify the OSDP reader connection.
 - A. Check the OSDP reader's device address and baud rate. The ODM-2000 should set these parameters; however, some readers may not apply the `osdp_COMSET` parameters because the readers may not support specific values. Verify the reader supports `osdp_COMSET`, and select values within the supported range.
 - B. If using Secure Channel, check that the ODM-2000's `SCBK_D` matches the reader's `SCBK_D`.

Cypress ODM-2000 Series OSDP Splitter Manual - OSDP Terminology

This section lists and defines in general terms OSDP terminology use in this manual.

Access Control Unit (ACU): Typically, the access controller, the ACU is the device on the OSDP bus that controls the PDs. The ACU only sends commands to the PDs and waits for replies.

Peripheral Device (PD): Typically a reader, but many other devices can be PDs, any device on the OSDP bus that is not the ACU. PDs receive commands from the ACU and send replies.

Device Address: OSDP Peripheral Devices are assigned an address, all PDs on the OSDP bus must have a unique address. This address is used in commands from the ACU and in replies from the PD to indicate which device the message is being sent to/from.

Baud Rate: Data transfer rate, expressed in bits per second.

Secure Channel Base Key (SCBK): 16 byte key set by the user used to initiate Secure Channel communication sessions.

Secure Channel Base Key Default (SCBK_D): Default SCBK value. Default value set by the manufacturer or the default value defined in the OSDP specification.

Secure Channel Session (SCS): OSDP communication sessions using the Secure Channel Protocol, which, among other things, encrypts the data payload in OSDP messages.

Unencrypted Communication Session: OSDP communication sessions without data payload encryption.

Broadcast Address: An ACU can discover a PD with an unknown address by using the broadcast address. The broadcast address is 7F (or 127 in decimal).

osdp_POLL: ACU command to inquire status changes or new input data.

osdp_NAK: Negative acknowledge reply from the PD. Indicates the PD had an error processing the previous command.

osdp_ACK: Positive acknowledge reply from the PD. The PD properly processed the previous command or nothing to report to ACU.

osdp_RAW: PD reply with card data payload. Card data is a raw string of bits.

osdp_KEYPAD: PD reply with keypad data payload. Keypad data is a string of ASCII characters.

osdp_ID: ACU command to request a device identification report.

osdp_PDID: PD reply with a device identification report.

Cypress ODM-2000 Series OSDP Splitter Manual - OSDP Terminology (Cont.)

osdp_CAP: ACU command to request a device capability report.

osdp_PDCAP: PD reply with a device capability report.

osdp_COMSET: ACU command to change a PD's Address and/or Baud Rate.

osdp_COM: PD reply to report its updated communication settings.

osdp_LED: ACU command to control LEDs on a PD.

osdp_BUZ: ACU command to control buzzers on a PD.

osdp_CHLNG: ACU command to begin the Secure Channel Session Connection Sequence.

osdp_CCRYPT: PD reply to begin the Secure Channel Session Connection Sequence.

osdp_SCRYPT: ACU command to finalize the Secure Channel Session Connection Sequence.

osdp_RMAC_I: PD reply to finalize the Secure Channel Session Connection Sequence.

osdp_KEYSET: ACU command to change a PD's SCBK. A PD only accepts this command while in a Secure Channel Session.