

EXP-2000_MAN 260520

Cypress Suprex® Expansion Solutions - Overview, Specifications

Product Overview: Cypress Expansion Pairs (EXP-2000) are used with Suprex Reader-Extenders to accommodate additional readers. The EXP-2000 is a set of Central and Remote expansion boards which connect to a Suprex pair using a 2-conductor RS-485 connection. Connect a total of 8 readers to the access controller using 1 Suprex pair and 7 Cypress EXP-2000 Expansion Module Sets (use 1 set per additional reader). The EXP-2000 Set supports a Wiegand input of 24-248 bits, the same I/O channels, and the same interface types as the Suprex Reader Extenders.

The EXP-1000 Expansion Module is a single unit, primarily used as a replacement part. It is half of the EXP-2000 and can be set to use as a Central or Remote unit, as can the individual EXP-2000 units.

Specifications			
Part Numbers	EXP-1000	UPC: 816684003165	Single Expansion unit - can be set to either Central or Remote
	EXP-2000	UPC: 816684003233	Expansion Module Set (Pair) - includes Central and Remote EXP
Physical	Dimensions of single unit, with enclosure		4.5" x 2.9" x 0.94" / 0.3 lbs. 11.43 x 7.37 x 2.39 cm / 0.14 Kg
Environmental	Storage Temperature		0°C to 70°C 32°F to 158°F
	Operating Temperature		0°C to 70°C 32°F to 158°F
	Enclosure		Extruded aluminum, not sealed or weather rated.
Electrical	Central and Remote Supply Voltage		8-16Vdc Current 300mA, per unit
	Relays	Max Switching	220Vdc 30W (resistive) 1A / 250Vac 37.5VA 1A
		Running Spec with load	30Vdc 1A (resistive) / 125 Vac 0.3A (resistive), 1x10 ⁵ operations @ 20°C
Data Interfaces	Wiegand (Default)		Accepts 24-248 bits Data 0 and Data 1
	Wiegand (No Filter)		Accepts 24-248 bits Data 0 and Data 1
	Strobed Rising		Accepts 24-248 bits Clock and Data
	Strobed Falling		Accepts 24-248 bits Clock and Data
	Unsupervised F/2F		Accepts 24-248 bits Data 1
Compatibility	Compatible Suprex Models		Cypress SPX-7200, SPX-7500, SPX-7400 series, and SPX-5600 series
	Non-compatible Suprex Models		Cypress SPX-1300 (single-reader RS-485 Suprex)
Additional Features	On-board relays to control door/gate		
	Auxiliary I/O available for LED signal and door/gate/panel status signal		
	Status LED and Supervision Relay (default off) monitor wireless connection status		
Warranty	Lifetime warranty		

Wire Recommendations

RS-485	PVC - Belden 9744 - 22 AWG 2 Twisted Pair, 4000 feet max Plenum - Belden 82741 - 22 AWG 2 Twisted Pair, 4000 feet max
Wiegand / LED	PVC - Belden 9942 or 8777 - 22 AWG 3 Pair Shielded, 250 feet max Plenum - Belden 82777 - 22 AWG 3 Pair Shielded, 250 feet max PVC - Belden 9873 - 20 AWG 3 Pair Shielded, 500 feet max Plenum - Belden 83606 or 85164 - 20 AWG 3 Pair Shielded, 500 feet max
Inputs / Outputs	PVC - Belden 8451 - 22 AWG 1 Pair, 1000 feet max Plenum - Belden 82761 - 22 AWG 1 Pair, 1000 feet max
Power	PVC - Belden 8461 - 18 AWG 1 Pair, 25 feet max Plenum - Belden 82740 - 18 AWG 1 Pair, 25 feet max

Cypress Suprex Expansion Solutions -Table of Contents

Table of Contents		
Topic	Page	
Overview and Specifications	2	
Physical Dimensions	4	
Central and Remote Pin Layout	5	
Typical Central Wiring Diagram	6	
Typical Remote Wiring Diagram	7	
3 Central EXP-2000 Wiring Diagram	8	
3 Central EXP-2000 Wiring Diagram	9	
Setup and Pre-Installation	10	
Configuring the EXP-2000	11-12	
EXP-2000 DIP Switches	13	
Diagnostic LED Behavior	14	
Accessory I/O	Accessory I/O Overview	15
	Central Relay Inputs	16
	Relay 1 & 2 I/O	17
	Remote Relay Inputs	18
	Relay 3 & 4 I/O	19
	LED I/O	20
	Aux I/O	21
Supervised Contacts	22-24	
Troubleshooting	25-26	
Installing External Pull-up Resistors	27	

Cypress Suprex Expansion Solutions - Dimensions

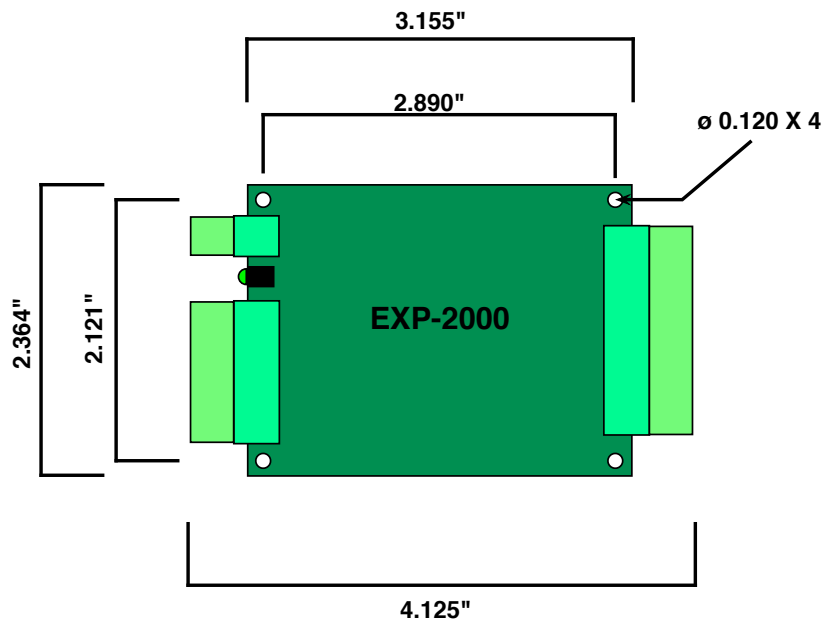
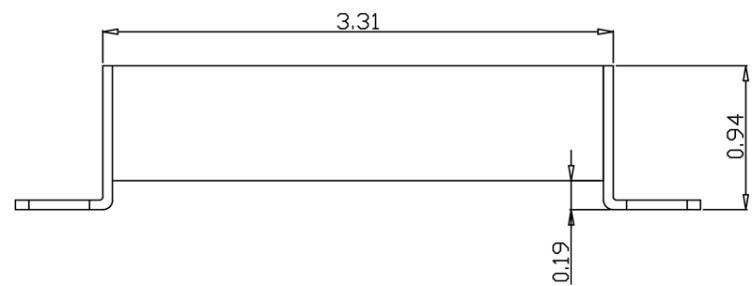
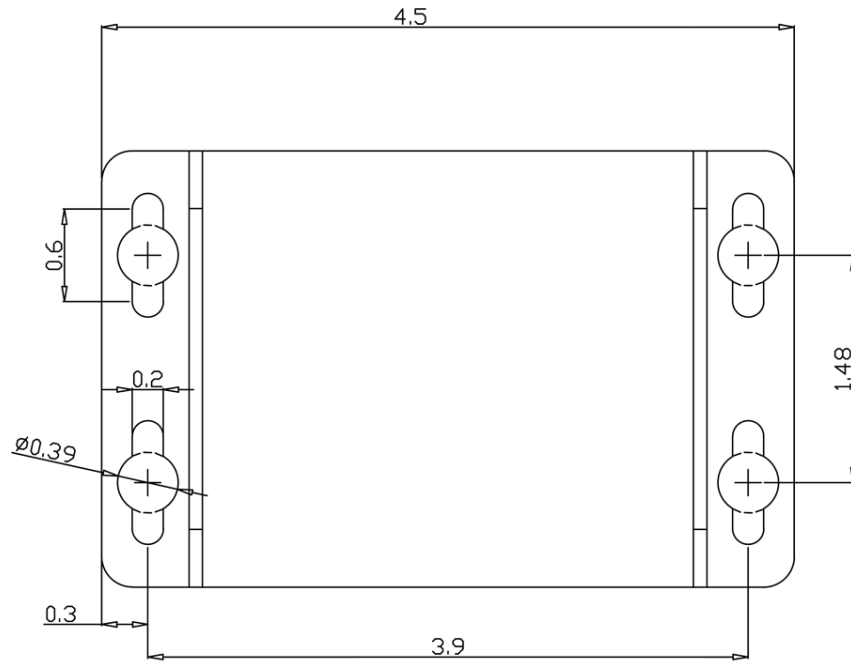

All dimensions are listed in inches.

Cypress Suprex Expansion Solutions - Central and Remote Pin Layout

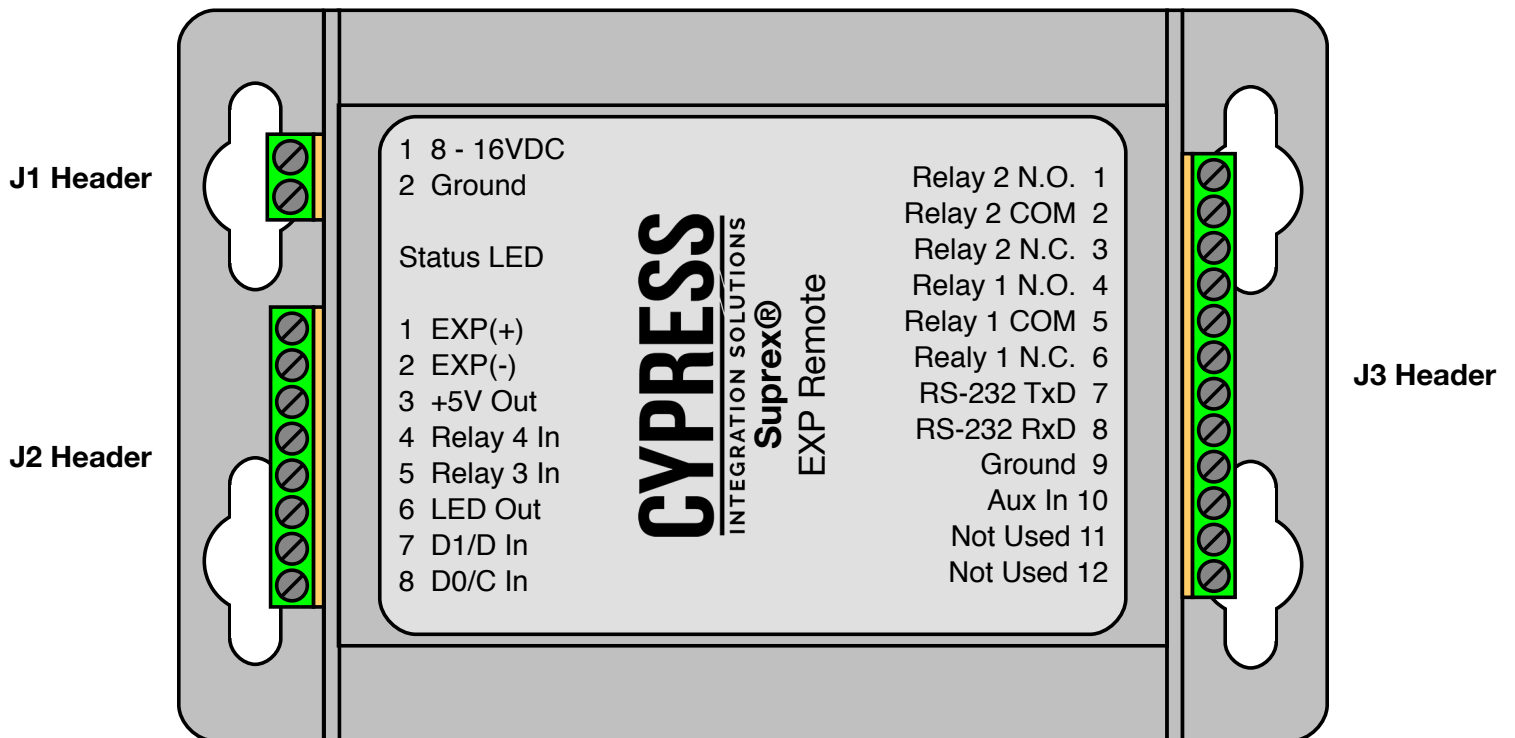
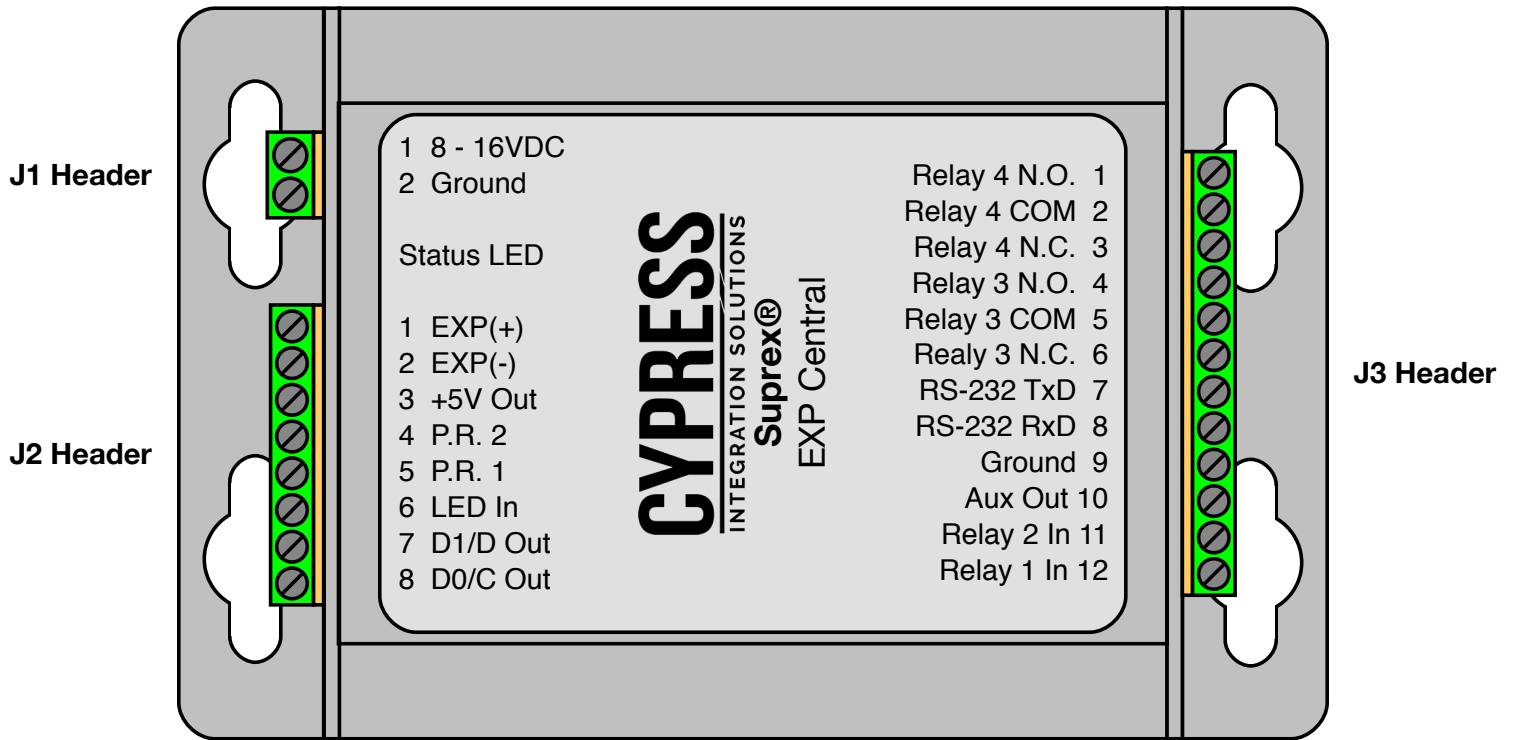

Cypress Suprex Expansion Solutions - Typical Central Wiring Diagram

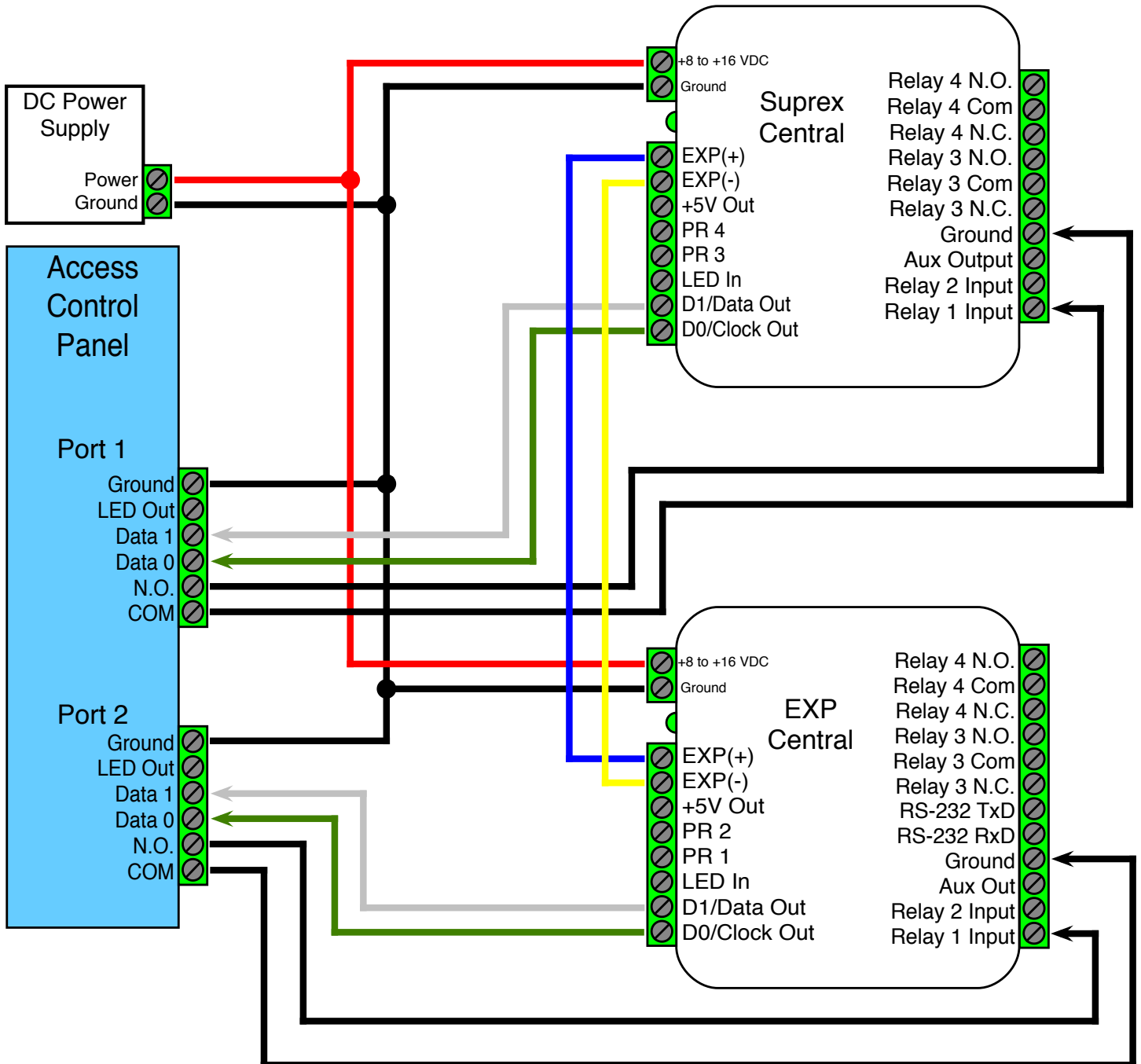

Cypress Suprex Expansion Solutions - Typical Remote Wiring Diagram

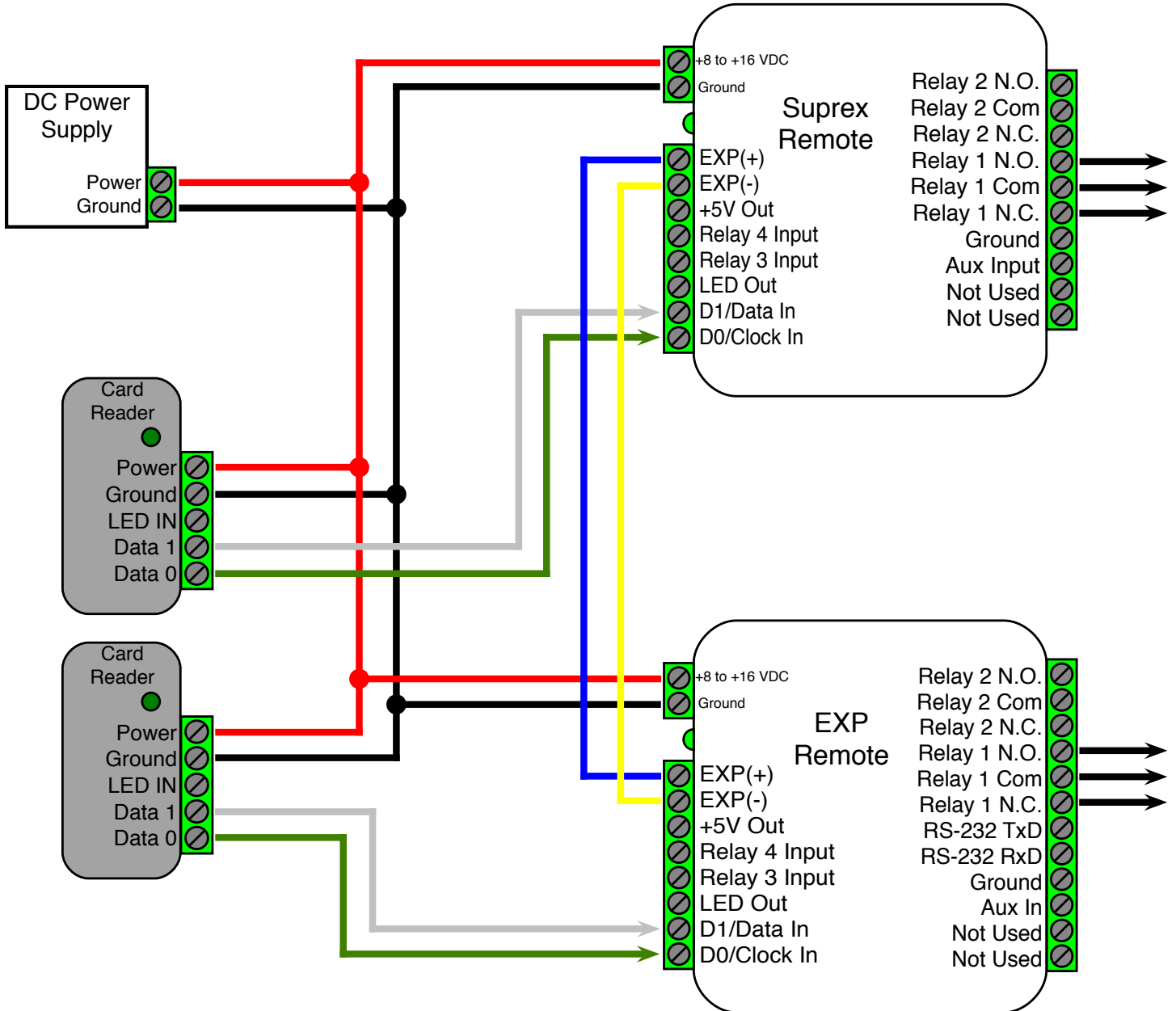

Cypress Suprex Expansion Solutions - 3 Central EXP-2000 Wiring Diagram

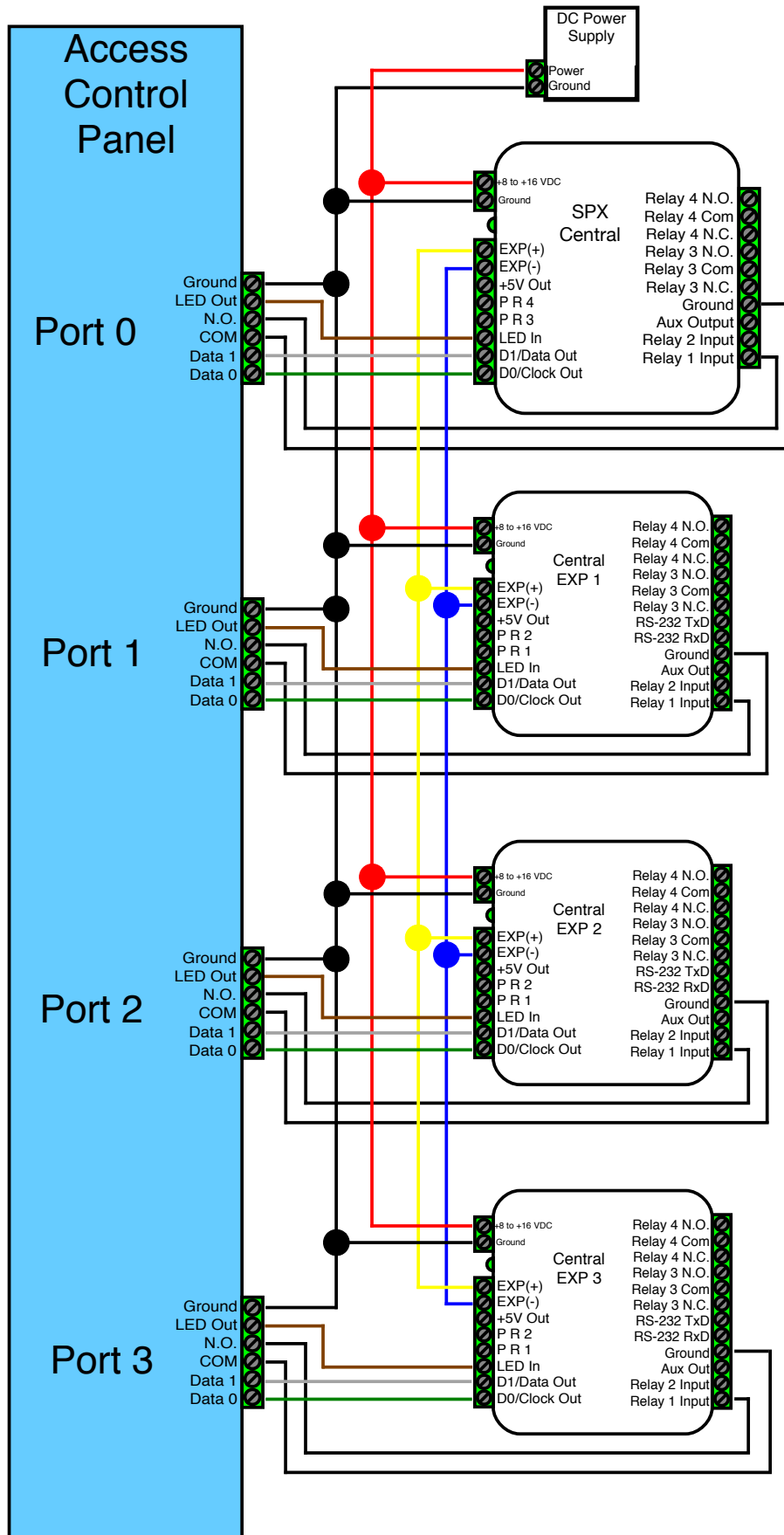

Cypress Suprex Expansion Solutions - 3 Remote EXP-2000 Wiring Diagram

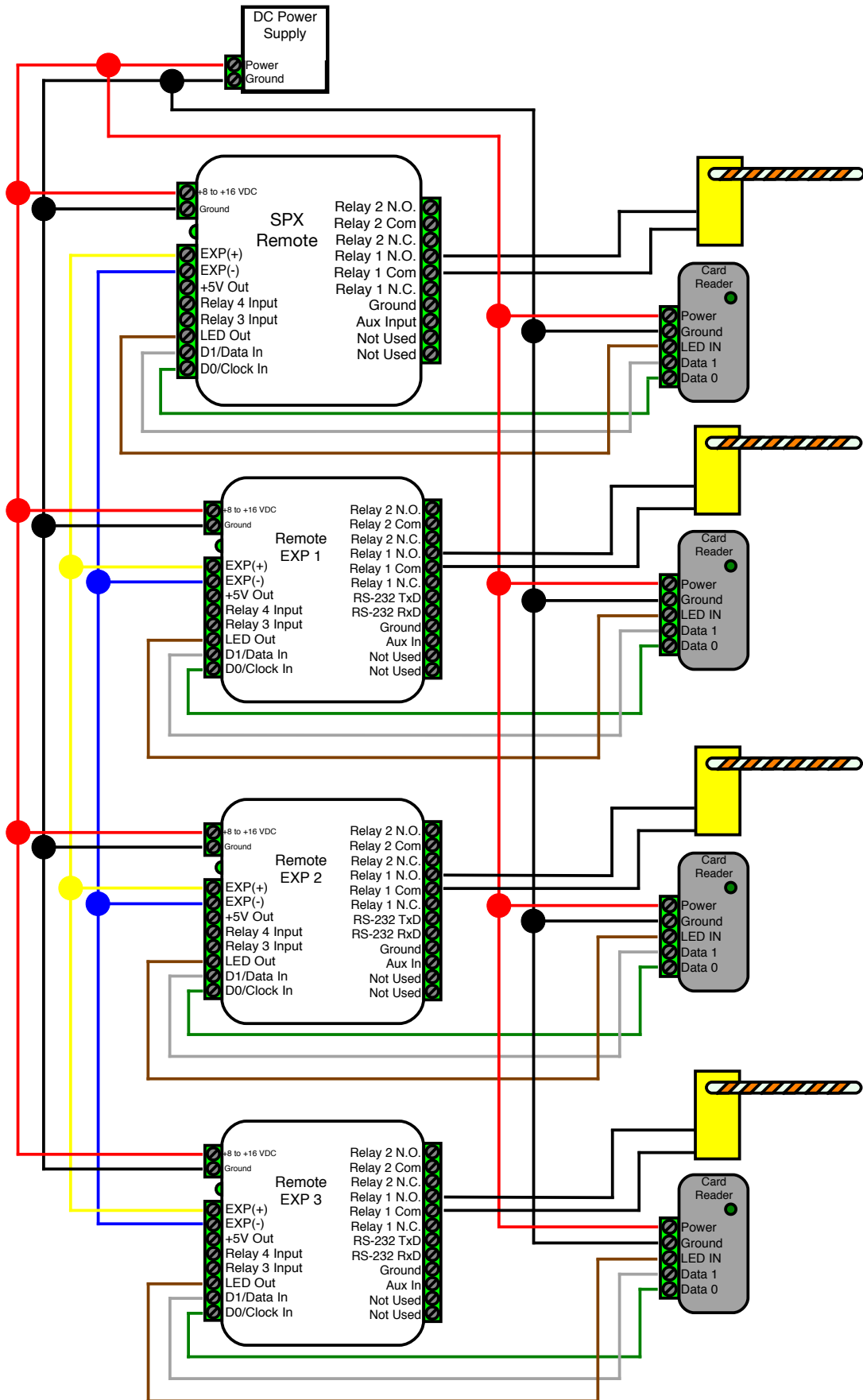

Cypress Suprex Expansion Solutions - Setup and Pre-installation

Unpacking:

Remove pouch contents (on packing exterior), then remove EXP-2000 units from packaging.

Inventory included items:

EXP-2000 Central EXP-2000 Remote Connector Sets (2) Warranty Quick Start Guide

Bench Testing:

Before installing the EXP-2000 units in the field they should be tested at a convenient benchtop location. This will make it easier to verify / change settings and check operation while both units are together, as it is more difficult to set up and test the units when they are apart. This is also an opportunity to become more familiar with the system.

Basic Bench Test (One EXP Pair):

1. Connect a suitable power supply to Suprex and EXP-2000 pair. For this bench test, the units can share the same power supply. Each unit needs to be supplied 8-16 VDC and approximately 300mA.
2. Connect the EXP-2000 Remote to the Suprex Remote, then connect the EXP-2000 Central to the Suprex Central: EXP(+) to EXP(+), and EXP(-) to EXP(-).
3. Connect the Suprex Central and Remote units together. Connect EXP(+) to EXP(+), and EXP(-) to EXP(-) between the Suprex Central unit and EXP Central units. This needs to be done the same way between the Suprex Remote unit and EXP Remote units (*see wiring diagram, pgs. 6-7*).
4. Apply power to the EXP-2000 and Suprex units. After a few seconds, the status LEDs on all four units should be flashing green. This indicates that the Suprex units are communicating and the EXP-2000 units are being properly polled.
5. On the EXP-2000 Central unit, touch a jumper wire to Ground and Relay 1 Input. Relay 1 on the EXP-2000 Remote unit should change state. There will be an audible click when the relay changes state. The state of the relay can be monitored by using a multimeter in continuity mode.
6. If a Wiegand reader is available, connect the EXP-2000 Remote unit to the reader (D0, D1, and ground). Connect the EXP-2000 Central to the access controller (D0, D1, and ground).
7. Present a credential to the reader and verify that it was received by the access controller.
8. Once these steps have been completed, the EXP-2000 units are ready to be installed in the field.

Final Field Installation Checklist:

- The EXP-2000 Central and access controller share a common ground.
- The EXP-2000 Remote and card reader share a common ground.
- The EXP-2000 pair has been set to the desired Polling Address.
- The EXP-2000 Central and Remote units are properly connected to the Suprex Central and Remote.

Cypress Suprex Expansion Solutions - Configuring the EXP-2000

This section explains how to configure the EXP-2000 Central and Remote units for use with a Suprex pair using the DIP switches located on the circuit board. To access these DIP switches, remove the circuit board from the enclosure: Remove either end plate by removing the two screws that hold it in place, then slide the circuit board out of the enclosure. More information about the DIP switches is listed in the EXP-2000 DIP Switches Section (see pg. 13).

Step 1: Configuring Suprex units to use with EXP-2000 pairs # of EXP-2000 Pairs

DIP Switches 6-8 on the Suprex units control how many EXP-2000 pairs will be polled by the Suprex units. By default, the Suprex units are configured not to poll any EXP pairs, so when EXP-2000 pairs are being used, the Suprex units must be reconfigured. The Central Suprex unit polls the Central EXP-2000 units, and the Remote Suprex polls the Remote EXP-2000 units. For this reason, both the Central and Remote Suprex units need to be configured for the total number of EXP-2000 pairs being used. Refer to the table to the right to see how to set DIP switches 6-8 for the number of EXP-2000 pairs. "0" is OFF, "1" is ON.

6	7	8	(Run Mode)
0	0	0	- None
0	0	1	- 1 Pair
0	1	0	- 2 Pairs
0	1	1	- 3 Pairs
1	0	0	- 4 Pairs
1	0	1	- 5 Pairs
1	1	0	- 6 Pairs
1	1	1	- 7 Pairs

Step 2: Setting EXP polling addresses

DIP switches 6-8 on the EXP-2000 units set the EXP-2000's polling address. By default, each EXP-2000 pair is set to polling address 1. If using only one EXP pair, it is not necessary to set a polling address. The available polling addresses are 1-7. Refer the Address Select Table to the right. "0" is OFF, "1" is ON. DIP Switches need to remain set during operation.

Each EXP-2000 pair needs to be set to a unique polling address. It is important to start addressing the EXP-2000 pairs at address 1 and go up from there. For example, if the Suprex units are configured to poll 4 EXP-2000 pairs, they will poll addresses 1, 2, 3, and 4. If one of the EXP-2000 pairs is set to polling address 6, it will not be polled by the Suprex.

6	7	8	Address Select
0	0	0	- Invalid
0	0	1	- Address 1
0	1	0	- Address 2
0	1	1	- Address 3
1	0	0	- Address 4
1	0	1	- Address 5
1	1	0	- Address 6
1	1	1	- Address 7

Step 3: Setting the interface type

DIP Switches 3-5 on the EXP-2000 units set the interface type. By default, the EXP-2000 pairs are set to Wiegand, but may be set to Wiegand No Filter, Strobed Rising (MR5), Strobed Rising (Dorado 644), Strobed Rising (Mag-Tek), Strobed Falling, and Unsupervised F/2F. Refer to the Interface Type Select Table to the right. Once the DIP Switches are set for the desired interface type, the DIP Switches need to remain set during operation.

All of the interface types, except for Wiegand No Filter, can process 24-248 bits. The lower bound is 24 bits, this eliminates noise on the data lines being processed as a credential data. Typically, credential data is at least 26 bits long.

The Wiegand No Filter interface type processes 4-248 bits of Wiegand data, and is used with Wiegand keypad readers. Most Wiegand keypad readers output each keypress as 4 or 8 bits, which is less than the 24 bit lower bound on the default Wiegand interface.

3	4	5	Interface Type Select
0	0	0	- Invalid
0	0	1	- Wiegand
0	1	0	- Wiegand No Filter
0	1	1	- Strobed Rising (MR5)
1	0	0	- Strobed Rising (Dorado 644)
1	0	1	- Strobed Rising (Mag-Tek)
1	1	0	- Strobed Falling
1	1	1	- Unsupervised F/2F

The Unsupervised F/2F interface type uses the Data 1 I/O pins.

Cypress Suprex Expansion Solutions - Configuring the EXP-2000 (*cont.*)

Step 4: Wiring the Central and Remote units to the Suprex

The EXP-2000 Central and Remote units connect to the Suprex Central and Remote units with a 2-conductor RS-485 connection. This RS-485 connection is between the EXP(+) and EXP(-) pins on both the Suprex and EXP units, EXP(+) to EXP(+), and EXP(-) to EXP(-).

If using multiple EXP-2000 pairs, the 2-conductor RS-485 connection needs to be daisy-chained (multi-drop) between the Suprex and EXP-2000 units (*see wiring diagrams, pgs. 6-7*).

Note: The interface type feature is supported by EXP-2000 units with firmware version .404 and newer. Firmware version .404 was released in September, 2019. The firmware version is written on the circuit board near the DIP switches.

Cypress Suprex Expansion Solutions - EXP-2000 DIP Switches



DIP Switch 2 sets the EXP to Central or Remote mode.

DIP Switch 1 sets the EXP to Test mode.

DIP Switches 6, 7, & 8 set the polling address of the EXP Central or Remote unit.

Each EXP Central and Remote pair must be set to a unique polling address (1-7). The default address is Address 1. Address 0 is not a valid polling address. The EXP-2000 units will not communicate with the Suprex units if not set to a valid polling address (see pg. 11).

Address Select

6	7	8	
0	0	0	- Invalid
0	0	1	- Address 1
0	1	0	- Address 2
0	1	1	- Address 3
1	0	0	- Address 4
1	0	1	- Address 5
1	1	0	- Address 6
1	1	1	- Address 7

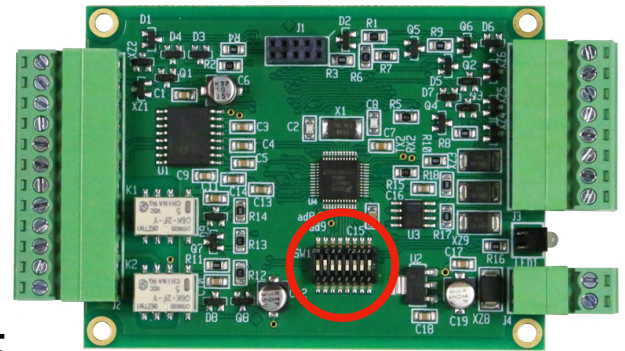
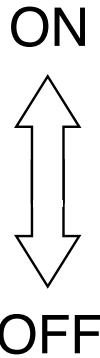

The DIP Switches are located on the circuit board (see photo, above). The circuit board will need to be removed from the enclosure in order to access them.

DIP Switch 1 sets the EXP to test mode when ON. Test mode is for factory testing, and should not be used in the field. The EXP-2000 unit will not function while in test mode. Supported by firmware version .404 or newer.

DIP Switch 2 sets the EXP as a Central when ON and as a Remote when OFF.

DIP Switches 3, 4, & 5 set the interface type (supported by firmware version .404 or newer).

Default Interface Type: Wiegand (24-248 bits).

Wiegand No Filter (4-248 bits), for use with Wiegand keypad readers.

Strobed Rising (24-248 bits), for use with strobed readers that use the rising edge of the waveform. Specific settings for MR5, Dorado 644, and Mag-Tek readers.

Strobed Falling, for uses with strobed readers that use the falling edge of the waveform.

Unsupervised F/2F, this interface uses a single data line, the Data 1 line.

Interface Type Select

3	4	5	
0	0	0	- Invalid
0	0	1	- Wiegand
0	1	0	- Wiegand No Filter
0	1	1	- Strobed Rising (MR5)
1	0	0	- Strobed Rising (Dorado 644)
1	0	1	- Strobed Rising (Mag-Tek)
1	1	0	- Strobed Falling
1	1	1	- Unsupervised F/2F

Cypress Suprex Expansion Solutions - Diagnostic LED Behavior

EXP-2000 diagnostic LED:

The diagnostic LED monitors the status of the communication between the EXP unit and the Suprex pair. This LED is located between the 2-pin and 8-pin header on the EXP units; the illuminated LED can be seen through the corresponding opening in the end plate.

Diagnostic LED colors and patterns indicate the following:

If the Central or Remote unit diagnostic LED is rapidly flashing green:

The Suprex and EXP units are communicating properly.

If the Central or Remote unit diagnostic LED is slowly flashing green:

The EXP is being polled by the Suprex unit, but the Suprex units are not communicating.

If the Central or Remote unit diagnostic LED is solid red:

When the diagnostic LED is solid red, it indicates that the EXP unit is not being polled by the Suprex unit (see *Troubleshooting, pgs. 25-27*).

If the Central or Remote unit diagnostic LED is solid green:

The EXP units are set to test mode. The EXP units are in test mode when DIP Switch 1 is ON. This test mode is for factory testing and has no use in the field. DIP Switch 1 needs to be switched up.

If the Central or Remote unit diagnostic LED is not illuminated:

When the diagnostic LED is not illuminating, then the unit is not being powered properly or the unit is damaged electrically and cannot power on.

Suprex diagnostic LED:

The Suprex Central and Remote units each have diagnostic LEDs to indicate one of several modes, including 2 indicators pertaining to communication between the Suprex and EXP units. The diagnostic LED on each of the Suprex units is located between the 2-pin and 8-pin header on the main circuit board.

EXP indicators shown on the Suprex unit diagnostic LEDs are listed below. Refer to the manual for your Suprex for other diagnostic LED indicators.

If the Central unit diagnostic LED is solid green:

There is a communication error between the Remote unit and one or more of the Remote EXP units, but the Suprex units are communicating.

If the Remote unit diagnostic is LED is solid green:

There is a communication error between the Central unit and one or more of the Central EXP units, but the Suprex units are communicating.

Note: The Suprex diagnostic LED will also display solid green when in Configuration Mode (DIP Switch 1 ON). See the Suprex manuals for more information.

Cypress Suprex Expansion Solutions - Accessory I/O Overview

The Cypress EXP-2000 provides additional data channels to support access control hardware such as door strikes, tamper alarms, REX (request to exit) status, etc. These signals are sent to and from the Central and Remote units without the need to run additional wiring. We refer to these data channels as Accessory I/O. Accessory I/O data channels include Relay 1, Relay 2, Relay 3, Relay 4, LED, and AUX. See pgs. 16-21 for details of each Accessory I/O operation and connection. Below is a table of the Accessory I/O pairs.

Relay I/O

The Relay I/O use active low inputs. When the Relay Inputs are floating (nothing connected) the inputs are set at 5Volts and the corresponding Relay Outputs will have continuity between COM and N.C. When the Relay Input is set to 0Volts (Ground) the input will activate the corresponding Relay Output. The Relay Outputs will have continuity between COM and N.O. when the relay is activated and will hold this state for as long as the Relay Input is set to 0Volts. The Relay Inputs can be tested by making a jumper connection to ground and monitoring the change in continuity of the Relay Outputs.

If using the relay outputs as wet relays, keep in mind the relay specifications (*see pg. 2*), as excessive voltage/current will damage the relays. (Damage may be instantaneous or become apparent over time.)

Relay 3 can function as a Supervision relay. The Supervision relay monitors the condition of the communication link between the Central and Remote units. The status of the EXP-2000 Supervision relay follows the Suprex Supervision relay. To enable the Supervision relay on the EXP-2000 units, enable the Supervision relay on the Suprex units. If the Supervision relay is enabled on the Suprex units, then it will be enabled on the EXP-2000 units. While in Supervision mode, Relay 3 is activated when the communication link between the Central and Remote is established and functioning. Relay 3 will deactivate (alarm condition) when either the Relay 3 Input on the remote is active (pulled low) OR the Remote unit is unable to communicate with the Central unit.

LED and AUX I/O

The LED and AUX I/O use active low inputs. When the inputs are floating (nothing connected) the associated output will be set to a high level (5V). When the input is set to 0Volts (Ground) the input will activate its associated output. All Accessory outputs are Open Collector type and will switch to Ground when activated and will hold this state as long as the input is set to 0Volts. Each input will have an associated output. Inputs can be tested by making a jumper connection to ground and monitoring the associated output.

INPUT	OUTPUT
Relay 1 Input (C)	Relay 1 COM, Relay 1 N.C., Relay 1 N.O. (R)
Relay 2 Input (C)	Relay 2 COM, Relay 2 N.C., Relay 2 N.O. (R)
Relay 3 Input (R)	Relay 3 COM, Relay 3 N.C., Relay 3 N.O. (C)
Relay 4 Input (R)	Relay 4 COM, Relay 4 N.C., Relay 4 N.O. (C)
LED Input (C)	LED Output (R)
Aux Input (R)	Aux Output (C)

(C) or (R) denotes the board on the Central or Remote unit where the pin is located.

Cypress Suprex Expansion Solutions - Accessory I/O - Central Relay Inputs

To activate the relay on the Remote unit, connect as shown below. These connections can be used to allow the Remote relay to operate a DOOR STRIKE, GATE, or other locking hardware. The diagram below shows two methods of triggering the relays. The first method uses a dry contact to trigger the relay. The second method shows the LED signal triggering the LEDs.

Relays 1 and 2 are available for accessory outputs at the Remote end. Either relay can be used to provide the Door Strike or Gate Activation function. This example uses Relay 1. The Relay Input pin is normally high (5Volts). When the Relay Input pin is pulled low (0Volts) the corresponding relay on the Remote unit will be activated. When the relay is activated, the Relay Output pins will change continuity from N.C. and COM to N.O. and COM (not shown in diagram).

Relay Input Wiring Example - Door Strike Follows Dry Contact

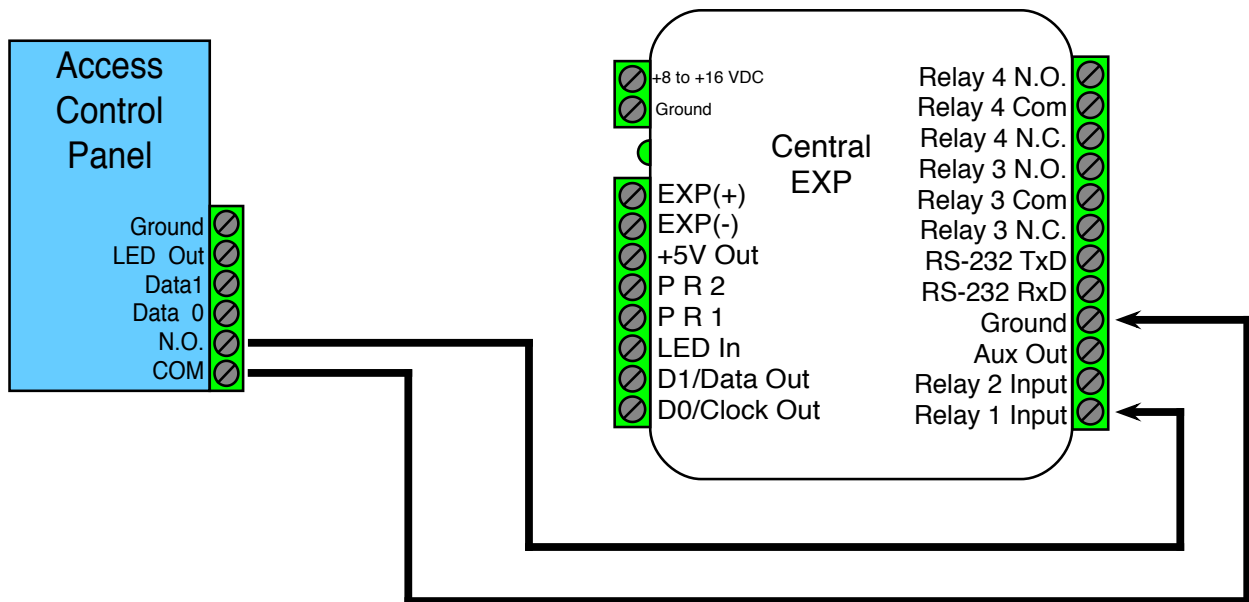

Relay Wiring Example - Door Strike Follows LED

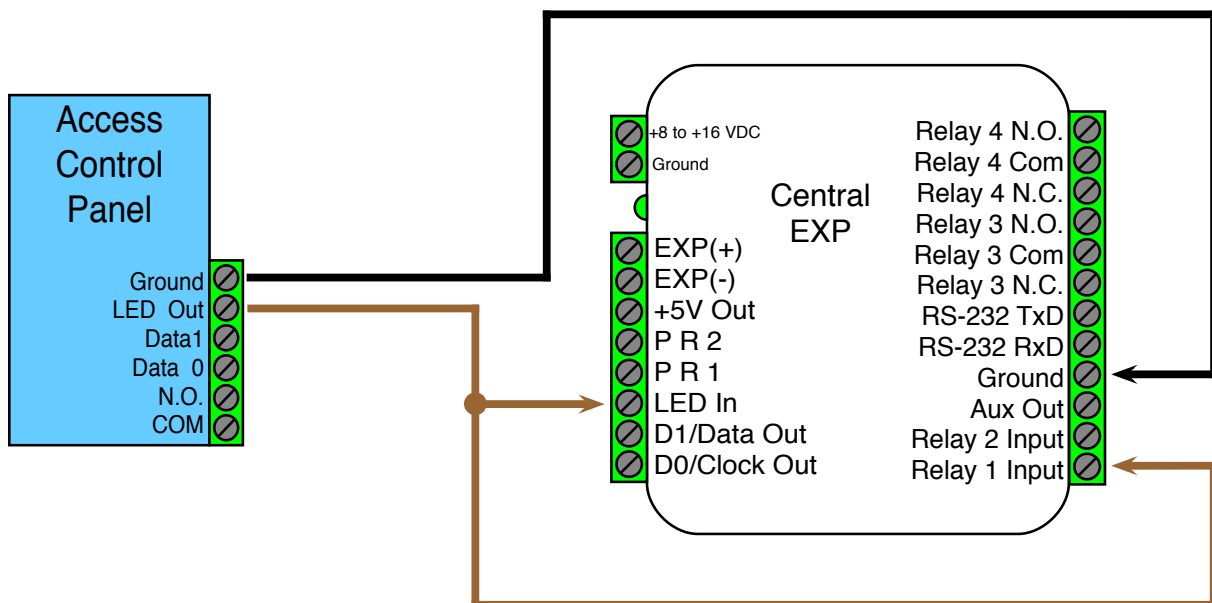

Cypress Suprex Expansion Solutions - Accessory I/O - Relay 1 & 2 I/O

Relay 1 I/O Diagram

This diagram illustrates the Relay 1 Outputs' state changes as the Relay 1 Input is set to 0Volts (connected to Ground) using a jumper connection.

The left side illustrates that when Relay 1 Input is not set to 0Volts, Relay 1 COM and Relay 1 N.C have continuity. The right side shows that when Relay 1 Input is set to 0Volts, Relay 1 COM and Relay 1 N.O. have continuity.

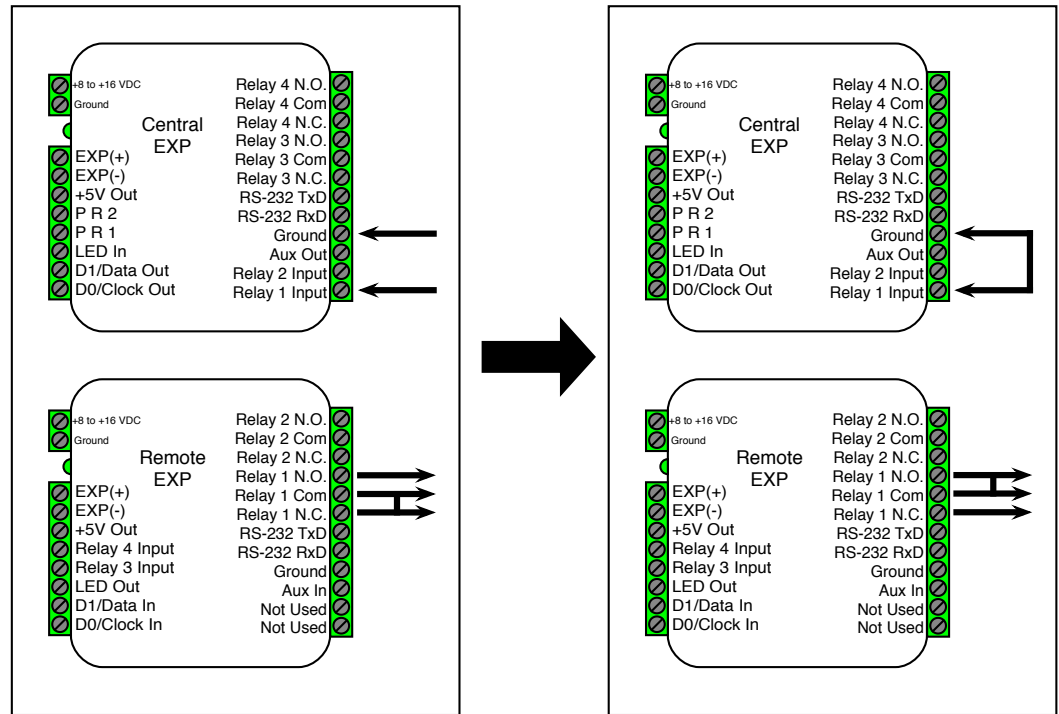

Relay 2 I/O Diagram

This diagram shows how the Relay 2 Outputs' state changes as the Relay 2 Input is set to 0Volts (connected to Ground) using a jumper connection.

The left side shows that when Relay 2 Input is not set to 0Volts, Relay 2 COM and Relay 2 N.C have continuity. The right side shows that when Relay 2 Input is set to 0Volts, Relay 2 COM and Relay 2 N.O. have continuity.

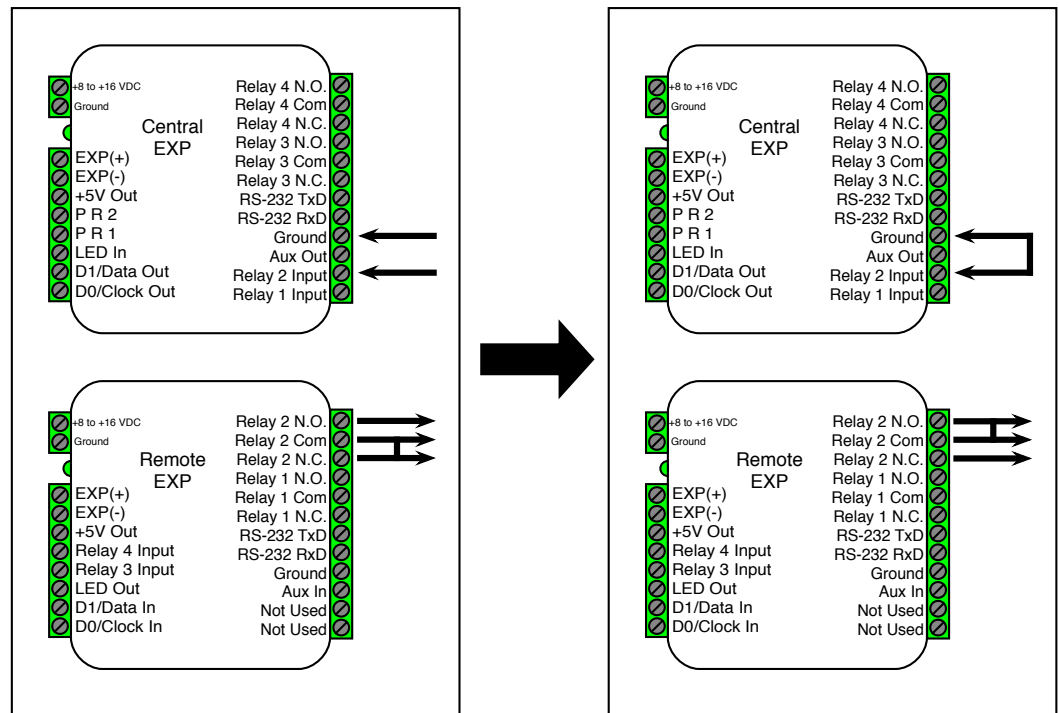

Cypress Suprex Expansion Solutions - Accessory I/O - Remote Relay Inputs

To activate the relay on the Central unit, connect as shown below. These connections can be used to operate a REX (Request to Exit) switch or other signals that need to go to the access panel.

Relays 3 and 4 are available for accessory outputs on the Central unit. Either Relay 3 or Relay 4 can be used. This example uses Relay 4. The relay input pin is normally high (5V). When the relay input pin is pulled low (0Volts), the corresponding relay on the Remote unit will be activated. When the relay is activated, the relay output pins will change continuity from N.C. and COM to N.O. and COM (not shown in diagram).

Important: Relay 3 can be used to send signals to the access panel while Supervision mode is active, but note that the outputs will be reversed. When Supervision mode is active and the Relay 3 Input Pin is normal (5V), the relay output pins will have continuity between N.O. and COM. When Supervision mode is active and the Relay 3 Input Pin is active (0Volts) the relay output pins will have continuity between N.C. and COM.

Relay Wiring Example - REX Switch

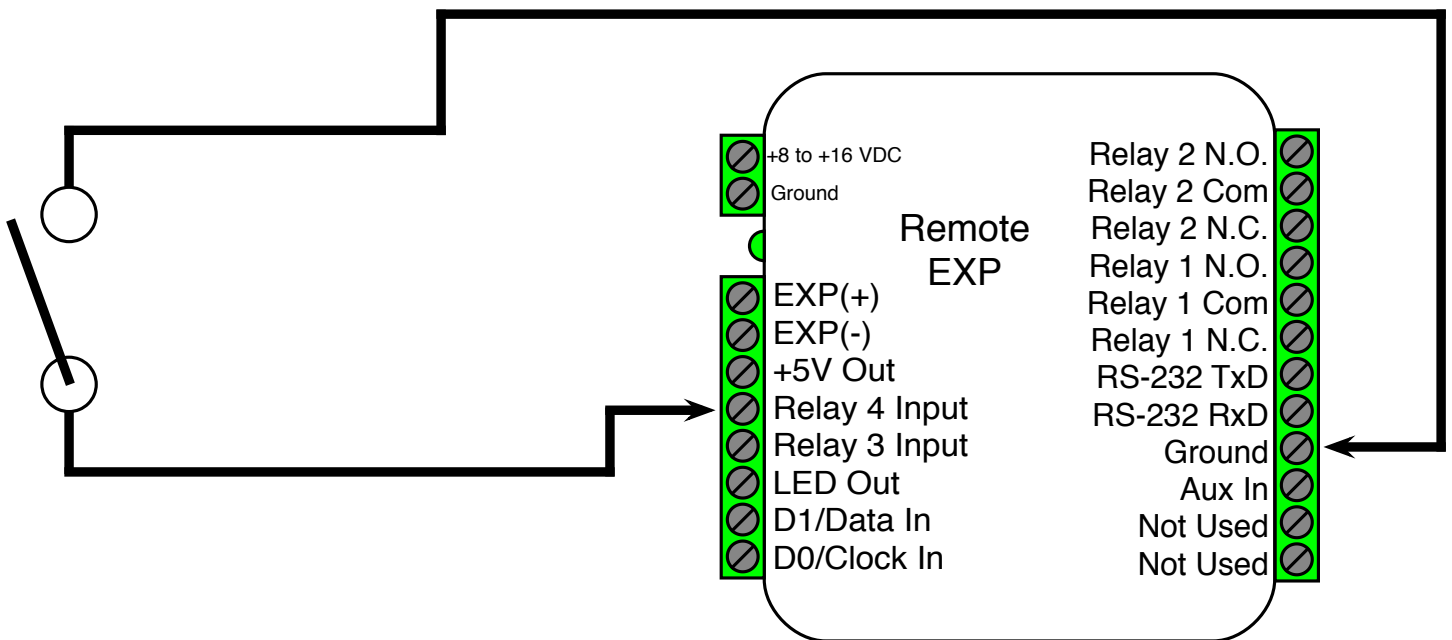

Cypress Suprex Expansion Solutions - Accessory I/O - Relay 3 & 4 I/O

Relay 3 I/O Diagram

This diagram shows how the Relay 3 Outputs' state changes as the Relay 3 Input is set to 0Volts (connected to Ground) using a jumper connection.

The left side shows that when Relay 3 Input is not set to 0Volts, Relay 3 COM and Relay 3 N.C. have continuity. The right side shows that when Relay 3 Input is set to 0Volts, Relay 3 COM and Relay 3 N.O. have continuity.

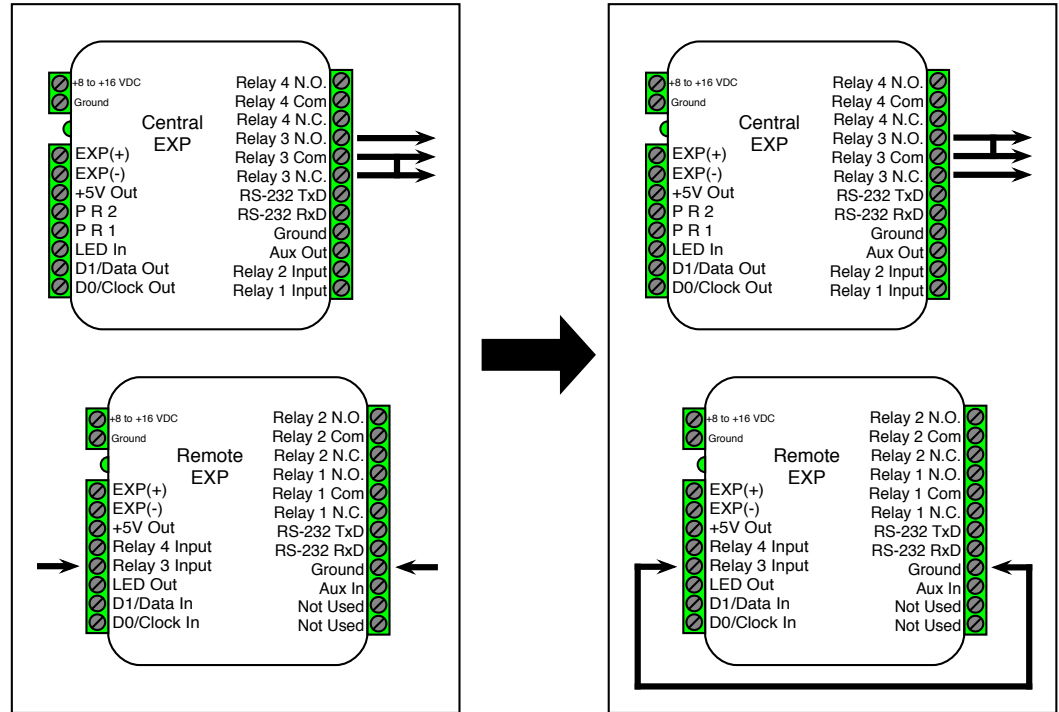

Relay 4 I/O Diagram

This diagram shows how the Relay 4 Outputs' state changes as the Relay 4 Input is set to 0Volts (connected to Ground) using a jumper connection.

The left side shows that when Relay 4 Input is not set to 0Volts, Relay 4 COM and Relay 1 N.C. have continuity. The right side shows that when Relay 4 Input is set to 0Volts, Relay 4 COM and Relay 4 N.O. have continuity.

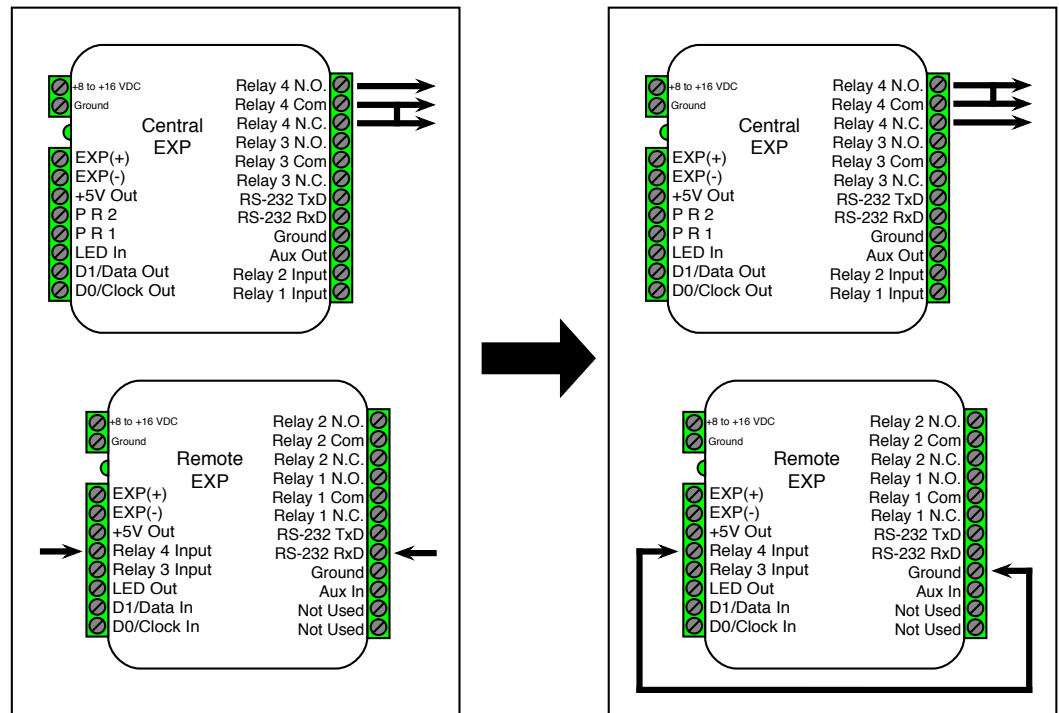

Cypress Suprex Expansion Solutions - Accessory I/O - LED I/O

For access control panels with a LED Output signal, the EXP-2000 is able to transmit this signal to the reader with the LED Input and LED Output pins. The LED In pin is a digital input and the LED Out pin is a digital output. The LED In pin has two states, 5V (high or normal) and 0Volts (low or active). The LED Out pin will mirror the state of the LED In pin.

The LED I/O Signal Diagram below shows how this signal is passed through the EXP-2000.

LED I/O Signal Diagram

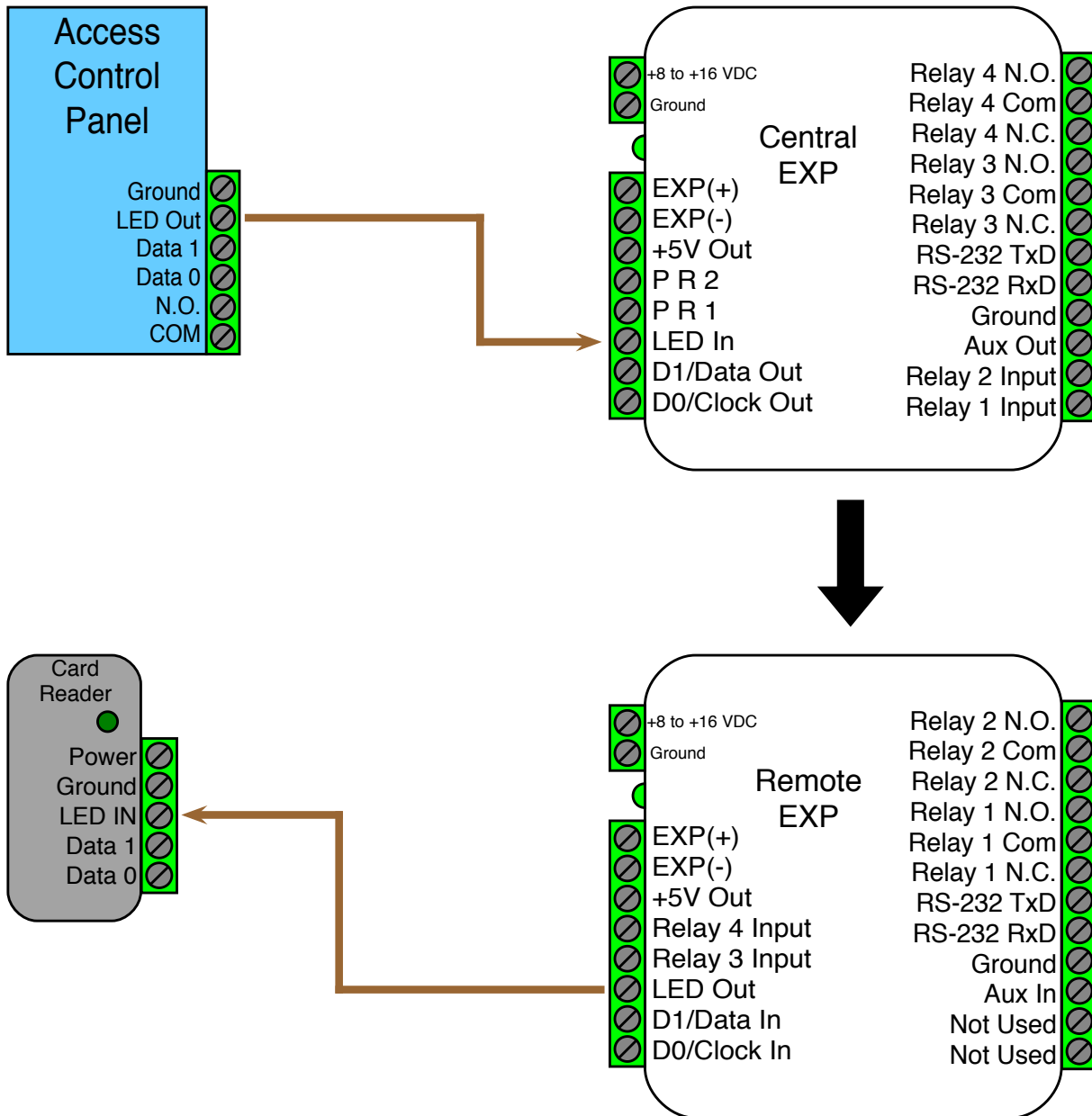

Cypress Suprex Expansion Solutions - Accessory I/O - AUX I/O

The EXP-2000 has an auxiliary I/O signal going from the reader side to the panel side. The EXP-2000 is able to transmit this signal to the panel with the AUX Input and AUX Output pins. The AUX In pin is a digital input and the AUX Out pin is a digital output. The AUX In pin has two states, 5V (high or normal) and 0Volts (low or active). The AUX Out pin will mirror the state of the AUX In pin.

The AUX I/O Signal Diagram below shows how this signal is passed through the EXP-2000.

AUX I/O Signal Diagram

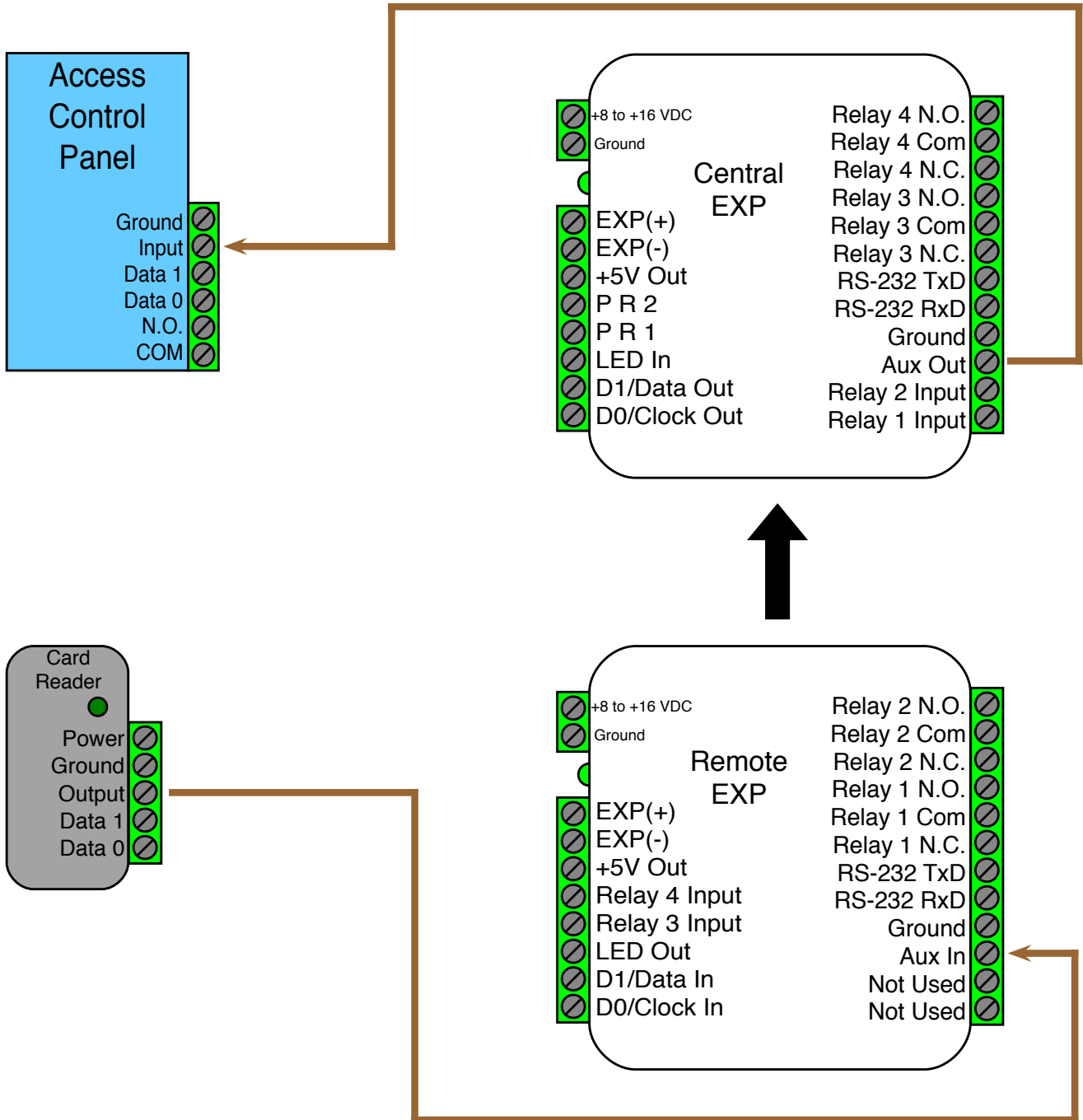

Cypress Suprex Expansion Solutions - Supervised Contacts

This section covers setting up a normally closed or normally open supervised contact using the EXP-2000. In both scenarios, the access controller sees 0 ohms when the supervised contact is normal. When the supervised contact is active, the access controller sees 1k ohms.

Theory of operation: The access control panel is looking for a certain resistance values at the supervised contact terminals. The EXP-2000 Central unit will provide these resistance values locally at the panel so that the correct supervised status is maintained. At the same time, the Remote unit must maintain supervision of the wires connected between the relay inputs and switch connected to the door or gate. The contact supervision is provided by the Remote unit. The EXP-2000 does this by comparing the value of the programming resistor on the Central unit with the resistance value on the Remote Relay Input pin. When there is a difference in the two values, the Relay Output on the Central unit is activated.

The normally closed configuration will be normal when the door/gate is closed, and active when the door/gate is open. The opposite is true for the normally open configuration, which is normal when the door/gate is open and active when the the door/gate is closed.

The P.R. 1 pin corresponds to Relay 3, and the P.R. 2 pin corresponds to Relay 4. Below is a step-by-step guide on setting up a supervised contact. Relay 4 is used for this example.

- **Step 1:** On the EXP-2000 Central, install a programming resistor between Ground and P.R. 2. This sets the normal state of the supervised contact. A 1k ohm resistor is used for a normally closed supervised contact, and a 2k ohm resistor is used for a normally open supervised contact.
- **Step 2:** On the EXP-2000 Central, connect a 1k ohm resistor between Relay 4 COM and Relay 4 N.C. Connect the one of the access controller inputs to Relay 4 COM and the other to Relay 4 N.C.
- **Step 3:** On the EXP-2000 Remote, connect a the switch and two 1k ohm resistors between Ground and Relay 4 In as shown in the diagrams.

In both normally closed or normally open setups, when the switch is open, the Relay 4 In pin sees 2k ohms and when the switch is closed, the Relay 4 In pin sees 1k ohms. The difference is the programming resistor on the Central unit. This determines the normal vs. active state of the supervised contact. When the resistance value on the Relay 4 In pin matches the resistance value on the P.R. 2 pin, the supervised contact is normal. When the resistance values do not match, the supervised contact is active.

Cypress Suprex Expansion Solutions - Normally Closed Supervised Contact

Door is Closed (normal state):

This diagram shows that when the door is closed, the supervised contact is in the normal state. With the switch closed, the resistance between Relay 4 Input and Ground is 1k ohms. This matches the resistance between P.R. 2 and Ground on the Central unit, causing the supervised contact to be in the normal state.

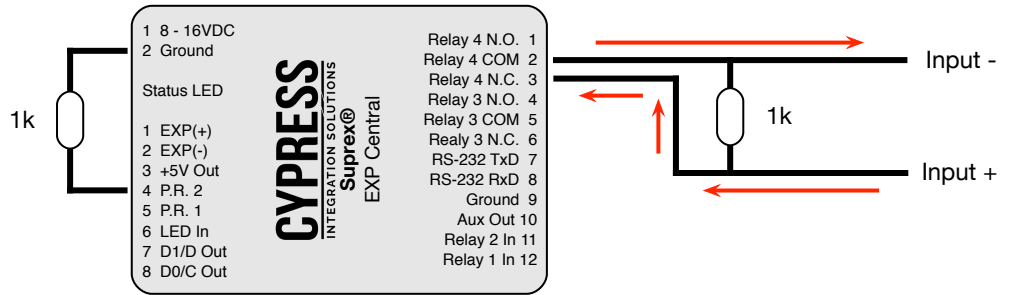

When the normally closed supervised contact is normal, Relay 4 is normal, with continuity between COM and N.C. The path of least resistance between the two inputs on the access controller is through Relay 4 COM and Relay 4 N.C. The resistance between the two access controller inputs is 0 ohms.

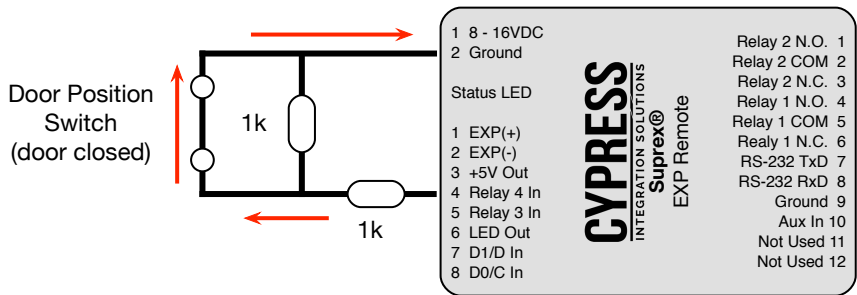

Door is Open (active state):

This diagram shows that when the door is open, the supervised contact is in the active state. With the switch open, the resistance between Relay 4 Input and Ground is 2k ohms. This does not match the resistance between P.R. 2 and Ground on the Central unit, causing the supervised contact to be in the active state.

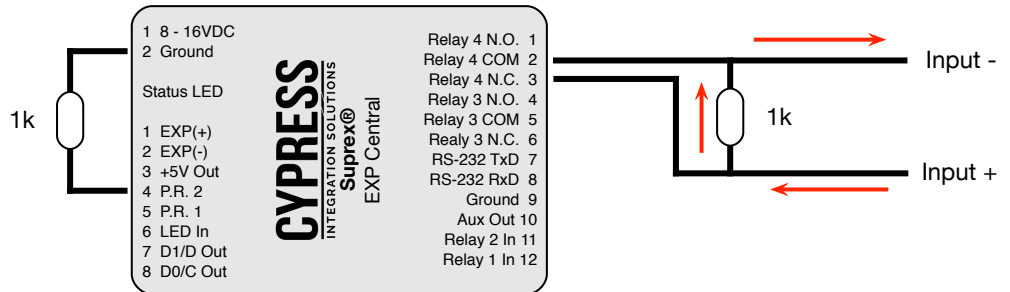

When the normally closed supervised contact is active, Relay 4 is active, with continuity between COM and N.O. The path of least resistance between the two inputs on the access controller is through the 1k ohm resistor. The resistance between the two access controller inputs is 1k ohms.

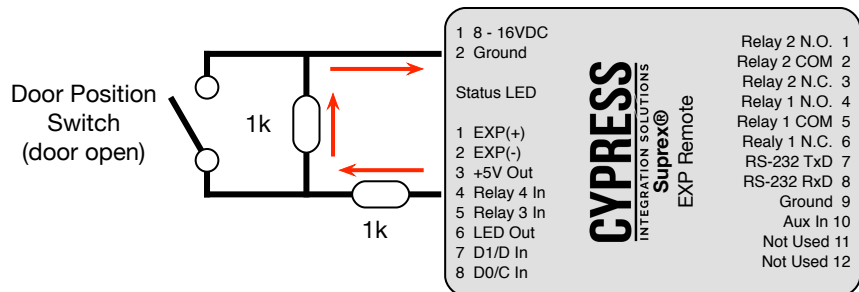

Cypress Suprex Expansion Solutions - Normally Open Supervised Contact

Door is Open (normal state):

This diagram shows that when the door is open, the supervised contact is in the normal state. With the switch open, the resistance between Relay 4 Input and Ground is 2k ohms. This matches the resistance between P.R. 2 and Ground on the Central unit, causing the supervised contact to be in the normal state.

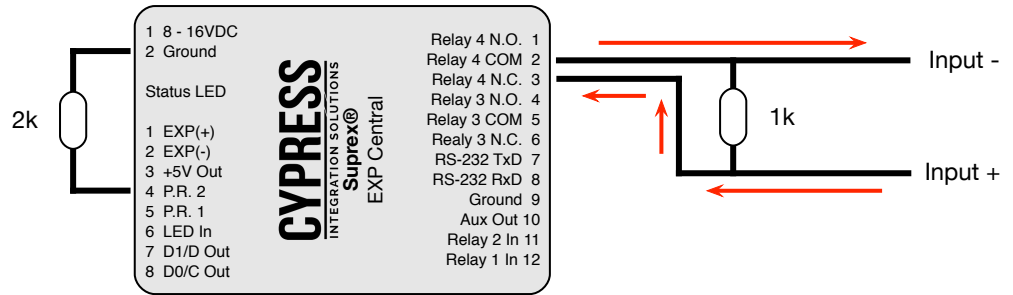

When the normally open supervised contact is normal, Relay 4 is normal, with continuity between COM and N.C. The path of least resistance between the two inputs on the access controller is through Relay 4 COM and Relay 4 N.C. The resistance between the two access controller inputs is 0 ohms.

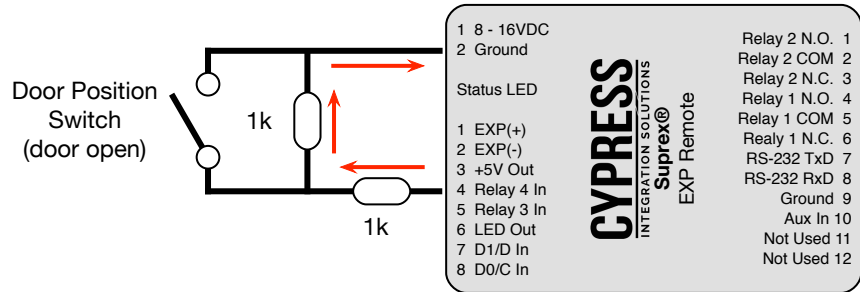

Door is Closed (active state):

This diagram shows that when the door is closed, the supervised contact is in the active state. With the switch closed, the resistance between Relay 4 Input and Ground is 1k ohms. This does not match the resistance between P.R. 2 and Ground on the Central unit, causing the supervised contact to be in the active state.

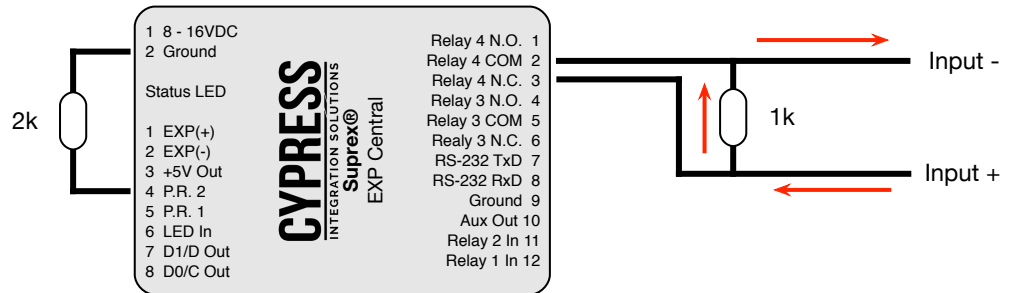

When the normally open supervised contact is active, with continuity between COM and N.O. The path of least resistance between the two inputs on the access controller is through the 1k resistor. The resistance between the two access controller inputs is 1k ohms.

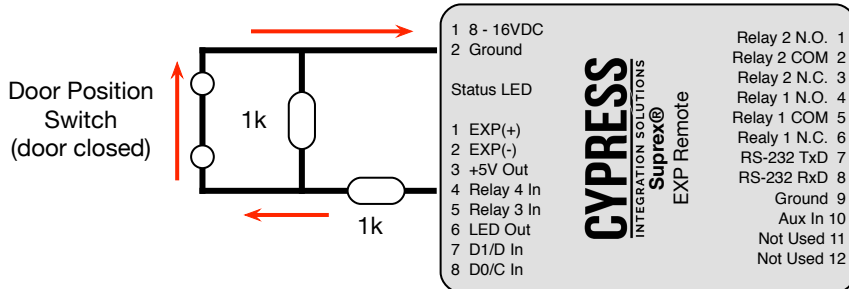

Cypress Suprex Expansion Solutions - Communication and Wiegand Troubleshooting

Troubleshooting the Wiegand I/O

Symptoms:

- No Wiegand data received at access controller. See troubleshooting steps 1, 3, and 4.
- Garbage (random) data at access controller. See troubleshooting steps 1 and 4.
- Consistent, incorrect data at access controller. See troubleshooting step 2.
- Inconsistent data at access controller. See troubleshooting steps 1 and 4.

Troubleshooting Steps:

1. **Ensure a common ground connection** (ground reference, data ground) between the EXP-2000 Central or Remote and the access controller or reader.
2. **Make sure the D0 and D1 lines are not reversed.** If the Wiegand data lines are reversed, the data will be inverted (0s become 1s, and 1s become 0s). If the access controller is receiving the same bad data for one credential, this may be the issue.
3. **Make sure both Wiegand data lines, D0 and D1, are connected** between the EXP-2000 Central and access controller, and between the EXP-2000 Remote and reader.
4. **Check Wiegand voltage.** The D0 and D1 lines should be idling at 5Vdc. Measure DC voltage between D0 and Ground, and between D1 and Ground. If the measured voltage is below 4.4V on either data line, there is a problem with the Wiegand connection. To determine which device is causing the Wiegand data line to be low, disconnect D0, D1, and Ground from the access controller or reader. Measure the DC voltage of D0 and D1 relative to Ground on the EXP-2000 Central or Remote and the access controller. Usually, one of the devices has a low data line and is causing the failure. If the voltage on the Wiegand data line is at 0V, then the transistor on that line is fully clamped to ground and the line cannot be recovered. If the voltage on the Wiegand data line is between 4.4V and 1V, it is possible to install an external pull-up resistor to bring the voltage back to 5V (see *diagram, pg. 27*).

Troubleshooting the EXP-to-Suprex Communication

Symptoms:

- Diagnostic LED on EXP unit is solid red.
- No Wiegand data or I/O signals are being sent to the access controller.

Troubleshooting Steps:

1. **Check the RS-485 connection** between the EXP-2000 unit and the Suprex unit at both Central and Remote locations. EXP(+) on the EXP connects to EXP(+) on the Suprex. EXP(-) on the EXP connects to EXP(-) on the Suprex.
2. **Check the circuit board for damage.** There are two diodes, one on the EXP(+) line and the other on the EXP(-). If these lines are hit with a voltage spike, these diodes can be damaged (see *photo below; diodes on the RS-485 lines are circled in red*). If there is visible damage to these diodes, then the RS-485 bus on the circuit board is damaged and will need to be replaced with a new EXP unit.

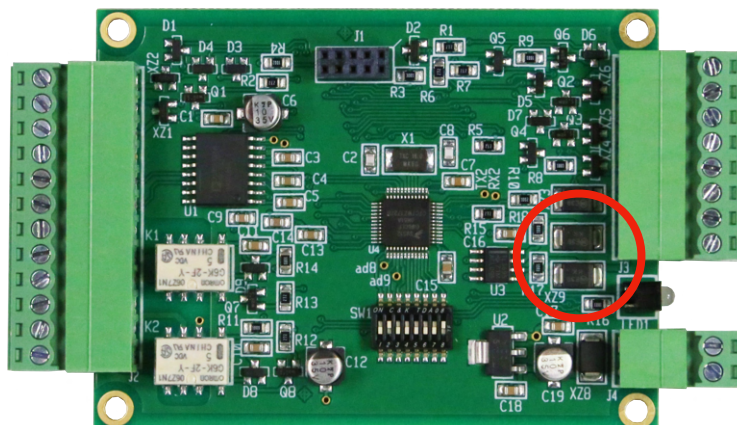

Troubleshooting Accessory I/O

Symptoms:

- Door/gate does not open on a valid credential read. See troubleshooting steps 1 and 3.
- LED on the reader does not change on a valid credential read. See troubleshooting steps 4 and 5.
- REX (Request to Exit) switch does not open door/gate. See troubleshooting steps 2, 3, 4 and 5.
- Door/gate is always open. See troubleshooting points 1, 2, and 3.

Troubleshooting steps:

1. **Relay Inputs 1 & 2** - Relay Inputs 1 & 2 are digital inputs. These pins are normally high at 5V and are active when pulled low to 0Volts. To test the functionality of the relay input pins, disconnect them from any output that is driving them. Measure DC voltage between the relay input pin and ground, the pin should be at 5V. When the relay input pin is connected to ground, it should be low at 0Volts, relative to ground. Abnormal voltage can prevent the corresponding relay from changing state. If the voltage on the relay input pin is at 0Volts, then the transorb on that line is fully clamped to ground and the line cannot be recovered. If the voltage on the Wiegand data line is between 4.4V and 1V, an external pull-up resistor may be installed to bring the voltage back to 5V, see *diagram, pg. 27*).
2. **Relay Inputs 3 & 4** - Relay Inputs 3 & 4 are analog inputs but function similar to digital inputs. The troubleshooting steps are the same as Relay Inputs 1 & 2. To test the functionality of the relay input pins, disconnect them from any output that is driving them. Measure DC voltage between the relay input pin and ground, the pin should be at 5V. When the relay input pin is connected to ground, it should be low at 0Volts, relative to ground. Abnormal voltage can prevent the corresponding relay from changing state. If the voltage on the relay input pin is at 0Volts, then the transorb on that line is fully clamped to ground and the line cannot be recovered. External pull-up resistors cannot be used to recover these analog inputs if the voltage is low. Usually, with these pins, either the transorb is fully clamped to ground or the processor pin they connect to is damaged.
3. **Relay Outputs** - The Normally Closed (N.C.) and Common (COM) pins are continuous when the relay input is normal (5V), and the Normally Open (N.O.) and COM pins are continuous when the relay input is active (0Volts). This continuity should be able to be observed with a multi-meter, changing when the relay input pin is connected and disconnected to ground (0Volts). When the relay is stuck, there will be no change in continuity when input is active, this indicates that the relay is damaged. If the other relay is not in use, test that relay and connect the inputs and outputs to it.
4. **LED and AUX Inputs** - These input pins are digital inputs and should normally be high at 5V and active when pulled low to 0Volts. To test the functionality of the relay input pins, disconnect them from any output that is driving them. Measure DC voltage between the relay input pin and ground; the pin should be at 5V. When the relay input pin is connected to ground, it should be low at 0Volts, relative to ground. Abnormal voltage can prevent the corresponding relay from changing state. If the voltage on the input pin is at 0V, then the transorb on that line is fully clamped to ground and the line cannot be recovered. If the voltage on the Wiegand data line is between 4.4V and 1V, it is possible to install an external pull-up resistor to bring the voltage back to 5V (*see diagram, pg. 27*).
5. **LED and AUX Outputs** - These pins are digital output pins and follow the state of the corresponding digital input. They are high at 5V while the input is normal (5V) and low at 0Volts when the input is active (0Volts). While measuring the DC voltage of the digital output with a multi-meter, connect the corresponding digital input to ground. The voltage of the digital output pin should be observed changing from 5V to 0Volts. If the voltage on the output line is at 0Volts, then the transorb on that line is fully clamped to ground and the line cannot be recovered. If the voltage on the output line is between 4.4V and 1V, it is possible to install an external pull-up resistor to bring the voltage back to 5V (*see diagram, pg. 27*).

Cypress Suprex Expansion Solutions - Installing External Pull-up Resistors

External pull-up resistors are used to pull up the voltage of damaged digital I/O pins to 5V, if the pin has been damaged and is between 1.0V and 4.4V. Through-hole resistors with values between 1k and 2.7k Ohms can be used. The higher the resistor value, the stronger the pull-up effect. For instance, using a lower value pull-up resistor may not pull the voltage all the way up to 5V. In these cases, a stronger pull-up resistor needs to be used. One end of the pull-up resistor is connected to the +5V Out pin; the other is connected to the low digital I/O pin (see *wiring diagram, below*).

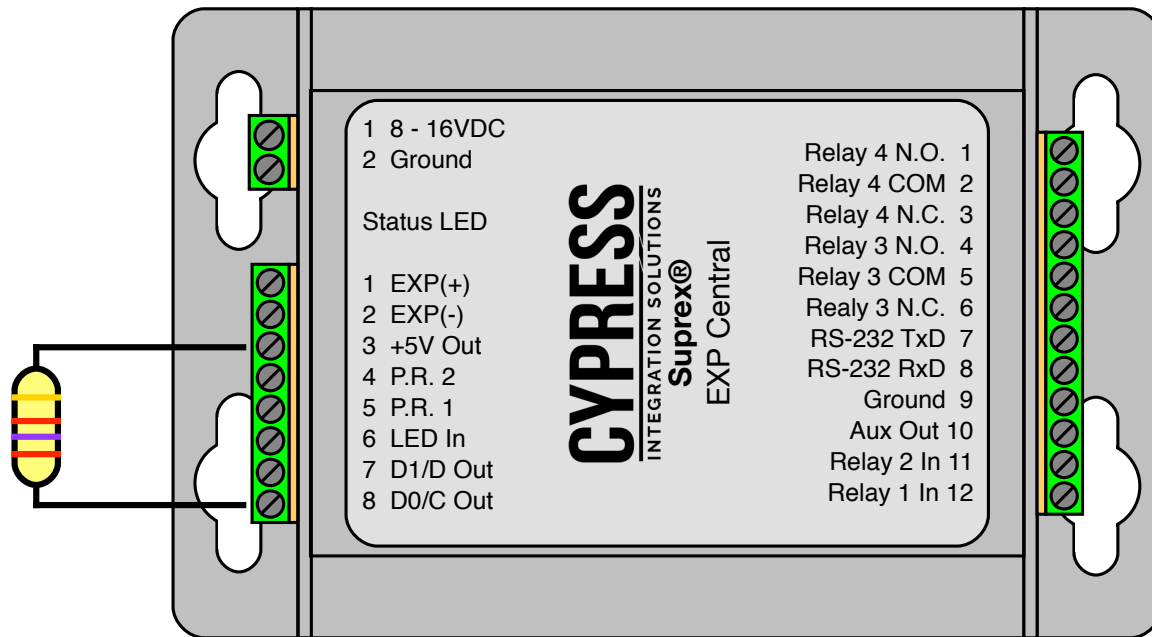

This example shows a 2.7k Ohm external pull-up resistor connected to the D0 Out pin on the EXP-2000 Central unit. If necessary, multiple external pull-up resistors can be installed if multiple digital I/O pins have a low voltage.